

Owner's Manual & Assembly Instructions

V01

Model No. HM10867 NP10867 RM108-A
 RMG108 RMW108 VH108-A
 WL10867

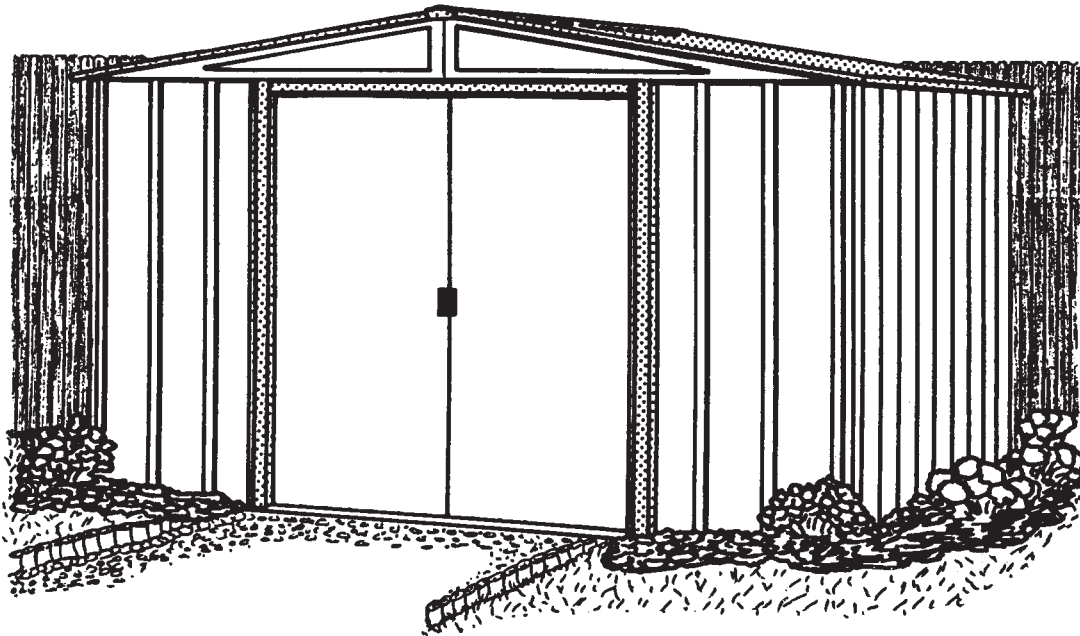

709431009

BUILDING DIMENSIONS * Size rounded off to the nearest foot



CAUTION: SOME PARTS HAVE SHARP EDGES. CARE MUST BE TAKEN WHEN HANDLING THE VARIOUS PIECES TO AVOID A MISHAP. FOR SAFETY SAKE, PLEASE READ SAFETY INFORMATION PROVIDED IN THIS MANUAL BEFORE BEGINNING CONSTRUCTION. WEAR GLOVES WHEN HANDLING METAL PARTS.

*Approx. Size	Foundation Size	Storage Area		Exterior Dimensions (Roof Edge to Roof Edge)			Interior Dimensions (Wall to Wall)			Door Opening	
				Width	Depth	Height	Width	Depth	Height	Width	Height
10' x 8'	121" x 92 3/4"	Sq. Ft.	Cu. Ft.	123 1/4"	95 1/4"	77 7/8"	118 1/4"	90"	76 5/8"	55 1/2"	65"
3,0 m x 2,3 m	307,3 cm x 235,6 cm	6,9 m ²	12,6 m ³	313,1 cm	241,9 cm	197,8 cm	300,4 cm	228,6 cm	194,6 cm	141,0 cm	165,1 cm

BEFORE YOU BEGIN....

A2

Owner's Manual

Before beginning construction, check local building codes regarding footings, location and other requirements. Study and understand this owner's manual.

Important information and helpful tips will make your construction easier and more enjoyable.

Assembly Instructions: Instructions are supplied in this manual and contain all appropriate information for your building model. Review all instructions before you begin, and during assembly, follow the step sequence carefully for successful results.

Flooring and Anchoring: Your storage building must be anchored to prevent wind damage. A base is necessary to construct a square and level building. Anchoring and base materials are not included with your building. We recommend the combined use of an **Arrow Floor Frame Kit** and an **Arrow Anchoring Kit** as an effective method of securing your building to the ground (Available by mail order or at your local dealer) or you may construct a base and anchoring system of your choice. Your assembly instructions provide information on a few methods commonly used to secure and level a storage building.

Parts and Parts List: Check to be sure that you have all the necessary parts for your building.

- All part numbers can be found on the parts. All of these numbers (before the -) must agree with the numbers on the parts list. The parts list is located on page 12.

- If you find that a part is missing, include the model number of your building and contact:

Arrow Group Industries, Inc. Customer Service Department
1101 North 4th Street Breese, Illinois 62230
1-800-851-1085

- Separate contents of the carton by the part number while reviewing parts list. The first few steps show how to join related parts to make larger sub assemblies which will be used later.

- Familiarize yourself with the hardware and fasteners for easier use during construction. These are packaged within the carton. Note that extra fasteners have been supplied for your convenience.

PLAN AHEAD....

A3

Watch the Weather: Be sure the day you select to install your building is dry and calm. Do not attempt to assemble your building on a windy day. Be careful on wet or muddy ground.

Teamwork: Whenever possible, two or more people should work together to assemble your building. One person can position parts or panels while the other is able to handle the fasteners and the tools.

Tools and Materials: These are some basic tools and materials you will need for the construction of your building. Decide which method of anchoring and the type of base you wish to use in order to form a complete list of the materials you will need.

<p>Required</p> <ul style="list-style-type: none"> • Eye Goggles • No. 2 Phillips Screwdriver (With Hardened Magnetic Tip) <p><small>Note: A power screwdriver or variable speed drill with Phillips-tip attachment can speed assembly by as much as 40%.</small></p>	<p>Required</p> <ul style="list-style-type: none"> • Work Gloves • Step Ladder • Utility Knife / Scissors • Pliers • Carpenter's Level • Tape Measure 	<p>Optional Time-Savers</p> <ul style="list-style-type: none"> • Wrench / Nut Driver • Electric / Cordless Drill • Square • String (for squaring frame) 	<p>Base Preparation</p> <ul style="list-style-type: none"> • Hammer and Nails • Spade or Shovel • Hand Saw / Power Saw • Lumber and/or Concrete
--	--	--	--

Selecting and Preparing Your Site: Before assembly, you will want to decide on a location for your building. The best location is a level area with good drainage.

- Allow enough working space for ease of moving parts into position during assembly. Be sure there will be enough space at entrance for doors to open fully and enough space around the building to be able to fasten the panel screws from the outside.

- Before you begin the first steps in assembling your parts, a base should be constructed and an anchoring system should be ready to use.

SAFETY FIRST...

A4

Safety precautions are important to follow throughout the construction of your building.

•Care must be taken when handling various pieces of your building since some contain sharp edges. Please wear work gloves, eye protection and long sleeves when assembling or performing any maintenance on your building.

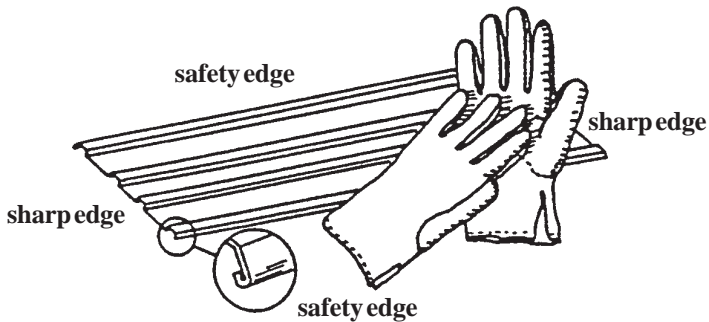

•Practice caution with the tools being used in the assembly of this building. Be familiar with the operation of all power tools.

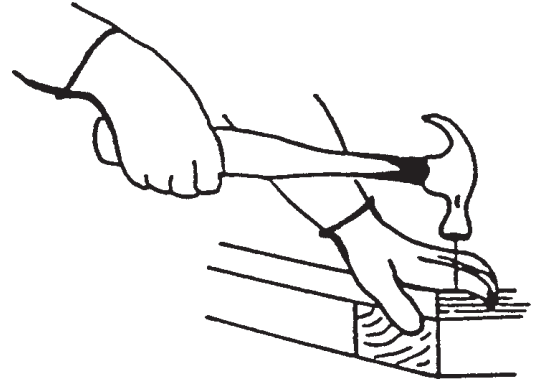

•Keep children and pets away from worksite to avoid distractions and any accidents which may occur.



•Do not attempt to assemble the building if parts are missing because any building left partially assembled may be seriously damaged by light winds. Call 1-800-851-1085

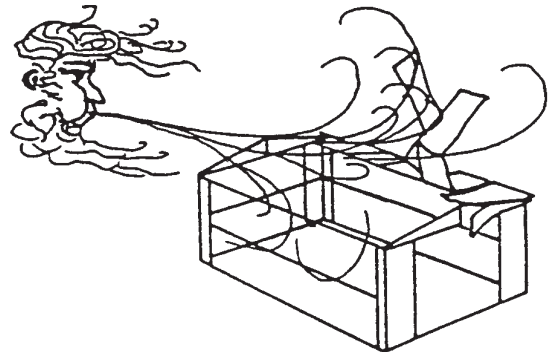

•Never concentrate your total weight on the roof of the building. When using a step ladder make sure that it is fully open and on even ground before climbing on it.

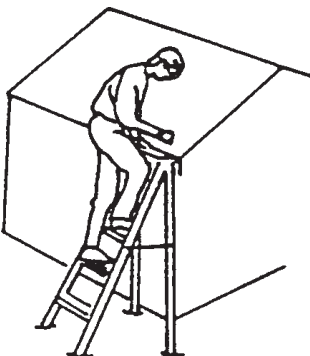

•Do not attempt to assemble the building on a windy day, because the large panels acting as a "sail", can be whipped about by the wind making construction difficult and unsafe.

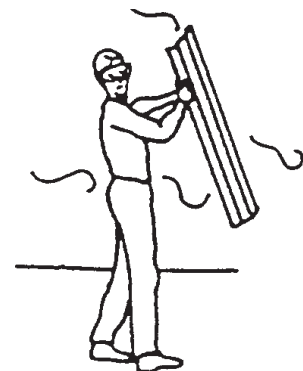

CARE & MAINTENANCE....

A5 Web

Finish: For long lasting finish, periodically clean and wax the exterior surface. Touch-up scratches as soon as you notice them on your unit. Immediately clean the area with a wire brush; wash it and apply touch-up paint per manufacturer's recommendation.

Roof: Keep roof clear of leaves and snow with long handled, soft-bristled broom. Heavy amounts of snow on roof can damage building making it unsafe to enter. In snow country, Roof Strengthening Kits are available for most Arrow Buildings for added protection against heavy snow accumulation.

Doors: Always keep the door tracks clear of dirt and other debris that prevent them from sliding easily. Lubricate door track annually with furniture polish or silicone spray. Keep doors closed and locked to prevent wind damage.

Fasteners: Use all washers supplied to protect against weather infiltration and to protect the metal from being scratched by screws. Regularly check your building for loose screws, bolts, nuts, etc. and retighten them as necessary.

Moisture: A plastic sheet (vapor barrier) placed under the entire floor area with good ventilation will reduce condensation.

Other Tips....

- Wash off inked part numbers on coated panels with soap and water.
- Silicone caulking may be used for watertight seals throughout the building.

Do not store swimming pool chemicals in your building. Combustibles and corrosives must be stored in air tight approved containers.

Keep this Owner's Manual and Assembly Instructions for future reference.

ACCESSORIES...

A6 WEB

ROOF STRENGTHENING (heavy snow load) KITS

Extra roof beams and gable braces designed for added protection against heavy snow accumulation. Increases the strength of your roof by 50%.

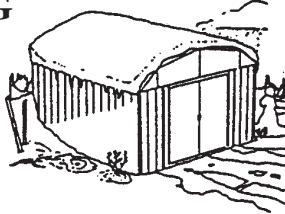

ANCHOR KITS

Model No. AK4

Anchor Kit contains heavy-duty steel augers, 60' (18 m) of steel cable and 4 cable clamps. No digging or concrete pouring, just insert cable under roof, over roof beams, into augers and twist augers into the ground. For buildings larger than 10'x9' (3,0 m x 2,6 m), use 2 kits.

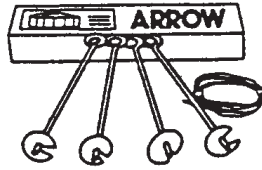

Model No. AK100

New concrete anchor system permits anchoring any size Arrow building directly to a concrete slab. Each kit contains heavy-duty, hot-dipped galvanized steel corner gussets and perimeter clips which fit over the floor frame and lag bolt into a concrete slab. Full assembly instructions and a 1/4" masonry drill bit are included.

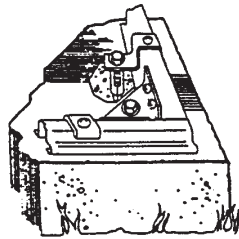

Model No. AK600

Earth Anchor Kit anchors any size Arrow building to the ground. Each kit contains heavy duty, hot-dipped galvanized steel corner gussets and 4 earth anchors.

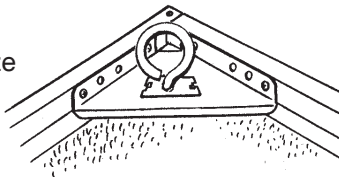

TOOL HANGING RACK

Model No. TH100

The perfect tool organizer. Twin 25 1/2" (64,8 cm) steel channels plus five heavy-duty snap-in hangers and a small tool holder for screwdrivers, pliers, etc. Holders slide along channel for fully adjustable spacing. Great for garage, basement, or the back of any door. Fits all Arrow storage buildings.

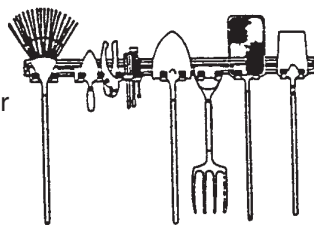

FLOOR FRAME KITS

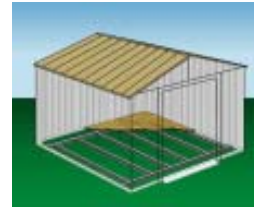

MODELS FB47410, FB5465, FB106-A
FB109-A and FB1014-A

A simple new floor frame system made of heavy-duty, hot-dipped galvanized steel. Use as base for plywood, sand or stone.

ATTIC KIT / WORKBENCH KIT

Model No. AT101

Heavy-duty galvanized steel bars that fit all 10' (3,0 m) wide Arrow buildings. They install quickly and easily to help organize space and create more useable space as an attic or workbench. Will hold up to 250 lbs. (113 kg) evenly distributed.



Some drilling required to fit buildings without mid-wall bracing.

SHELF UNITS

Heavy-duty, galvanized steel shelf units help organize storage space. They easily mount on the wall or sit on the floor. Fits all Arrow buildings.*

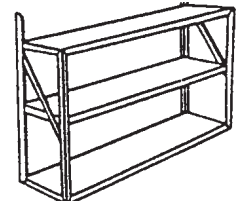
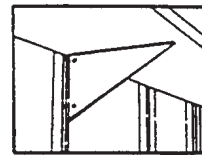
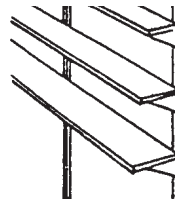

Model No. SS404

- Makes 8" to 12" (20,3-30,5 cm) wide shelves in any length.
- Brackets, braces, hardware included. Lumber is not included.

Model No. SS900-A

- Grey color
- 3 shelves
- Holds up to 85 lbs. (38 kg) (even weight distribution)

* Some drilling required to fit buildings without mid-wall bracing.

THIS
PAGE
WAS
LEFT
BLANK
INTENTIONALLY

THIS
PAGE
WAS
LEFT
BLANK
INTENTIONALLY

Foundation

A09

The Foundation For Your Building



OPTION 1: ARROW FLOOR FRAME KIT: (Order No. FB109-A or 68385-A)

Arrow has the best base for your building in this simple kit. It keeps stored items above the ground. This kit should be used with one of the following:

A. To support a plywood deck **B.** To be filled with sand. We recommend the combined use of **1.** an **ARROW FLOOR FRAME KIT** and **2.** an **ARROW ANCHORING KIT** as an effective method of securing the building to the ground. **Allow 1 - 2 hours for construction.**

OPTION 2: Wood Platform

If you decide to build your own foundation, be sure to select the appropriate materials.

These are the recommended materials for your foundation:

- 2 x 4's (38 mm x 89 mm) Pressure Treated Lumber
- 5/8" (15,5 mm) 4 x 8 (1220 mm x 2440 mm) Plywood-exterior grade
- 10 & 4 penny Galvanized Nails
- Concrete Blocks (optional)

The platform should be level and flat (free of bumps, ridges etc.) to provide good support for the building. The necessary materials may be obtained from your local lumber yard.

To construct the foundation follow instructions and diagram.

Construct frame (using 10 penny galvanized nails)
Measure 16"/24" (40,6 cm/61,0 cm) sections to construct inside frame (see diagram)
Secure plywood to frame (using 4 penny galvanized nails)

Allow 6 - 7 hours for construction.

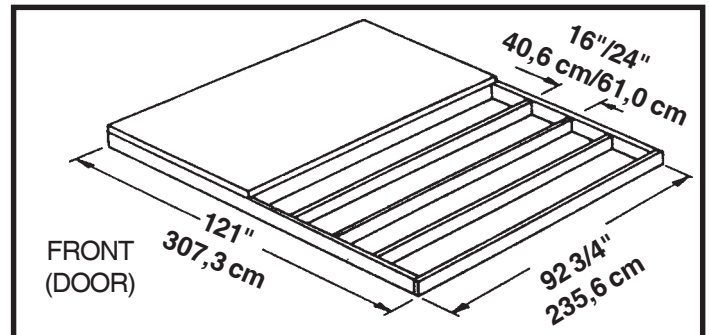

Note: Platform/Slab will extend 9/16" (1,4 cm) beyond floor frame on all four sides. Seal this 9/16" (1,4 cm) of wood with a roofing cement (not included), or bevel this 9/16" (1,4 cm) of concrete when pouring, for good water drainage.

OPTION 3: Concrete Slab

The slab should be at least 4" (10,2 cm) thick. It must be level and flat to provide good support for the frame.

The following are the recommended materials for your foundation.

- 1 x 4's (19 mm x 89 mm) (will be removed once the concrete cures)
- Concrete
- Sheet of 6 mil plastic
- We recommend for a proper strength concrete to use a mix of:
1 part cement ● 3 parts pea sized gravel ● 2 1/2 parts clean sand

Prepare the Site/Construct a Foundation

1. Dig a square, 6" (15,2 cm) deep into the ground (remove grass).
2. Fill up to 4" (10,2 cm) in the square with gravel and tamp firm.
3. Cover gravel with a sheet of 6 mil plastic.
4. Construct a wood frame using four planks of 1x4 (19 mm x 89 mm) lumber.
5. Pour in concrete to fill in the hole and the frame giving a total of 4" (10,2 cm) thick concrete. Be sure surface is level.

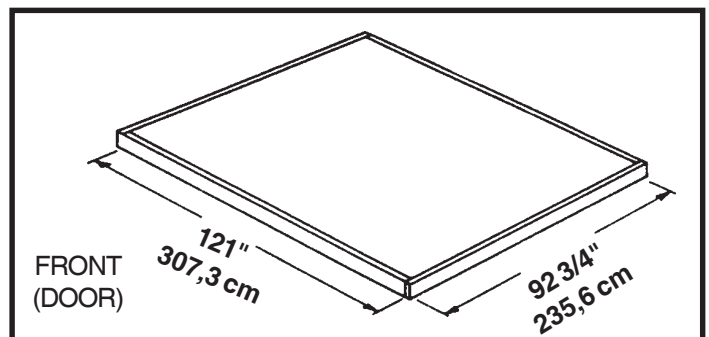

Note: Finished Slab dimensions, with lumber removed.

Allow 3 - 5 hours for construction and a week for concrete curing time.

Anchoring

A10

Anchoring Down The Building

It is important that the entire floor frame be anchored after the building is erected.

Below are recommended ways of anchoring.

Arrow Anchoring Kit: (Model No. AK4 or 60298)

Recommended for use with **any** suggested **base**.

Contains: 4 Anchors with Cable, Clamps and installation instruction.

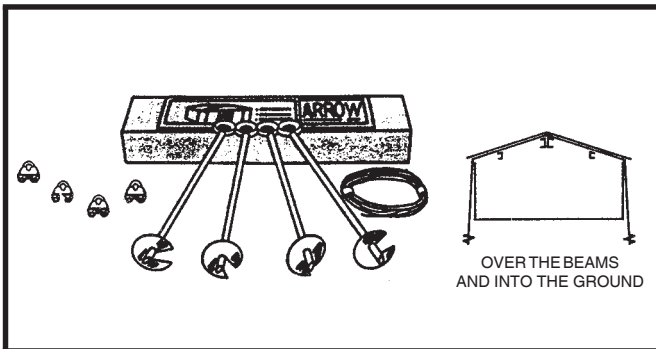

Anchoring into Wood/Post:

Use 1/4" (6 mm) Wood Screws. There are 1/4" (6 mm) dia. holes provided in the frames for proper anchoring.

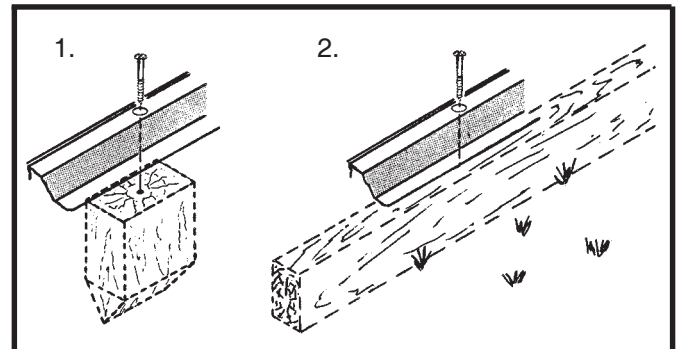

Arrow Anchoring Kit: (Model No. AK100 or 68383)

Recommended for use with the **concrete** base.

Contains: Corner gussets, perimeter clips, hardware, 1/4" masonry drill bit and installation instruction.

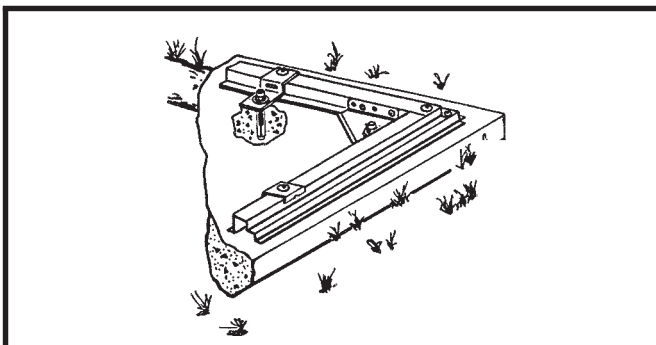

Anchoring into Concrete:

1. For poured concrete slab or footing or patio blocks: Use 1/4" x 2" (6 mm x 51 mm) Lag Screws.
2. For Anchor Post of Concrete poured after building is erected: Use 1/4" x 6" (6 mm x 152 mm) Lag Screws.

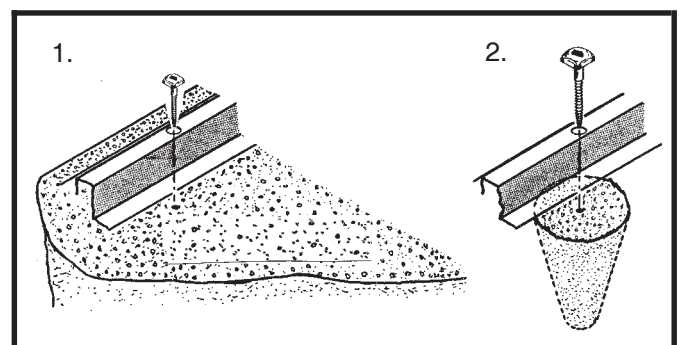

Hardware

A11

Remove from bag of screws
and save for the last step



65103
#8-32 Hex Nut (163)



65900A
#10Bx1/2" (13 mm)
Black Screw (8)
(Packed with Screws)



65923
#8-32x3/8" (10 mm)
Bolt (163)



65004
#8Ax5/16" (8 mm)
Screw (328)

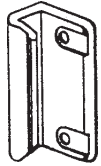

66045
Handle (2)

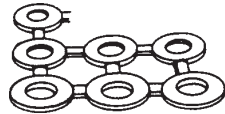

66646
Washer (377)
(10 sheets of 40)



65109
#8-32 Acorn Nut (4)
(Packed with Screws)

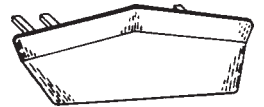

67468
Peak Cap (2)
(Arrow Logo)



66769
Door Slide (4)

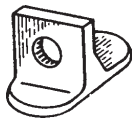

66382
Lower Door Guide (4)

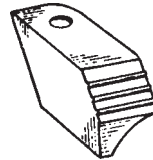

66183
Roof Trim Cap
(2 right & 2 left)

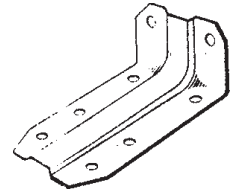

6228
Track Support (2)



5971
Roof Beam Bracket (4)



67293
Weather Stripping (1)

Parts List

V12

Assembly Key No.	Part Number	Part Description	Quantity in Carton	Check List
1	3719	Door Handle Brace	2	
2	8200	Wall Panel (Side)	4	
3	9374	Front Wall Panel	2	
4	9365	Front Wall Channel	2	
5	5986	Rear Wall Angle	2	
6	6000	Right Gable	2	
7	6001	Left Gable	2	
8	10497	Horizontal Door Brace	4	
9	6300	Vertical Door Brace	2	
10	6403	Door Track Splice	1	
11	9366	Door Track	2	
12	6627	Wall Panel	6	
13	6529	Roof Panel	2	
14	6635	Gable Brace	2	
15	10477	Right Door	1	
16	10477	Left Door	1	
17	7483	Roof Panel	4	
18	9370	Door Jamb	2	
19	9917	Rear Wall Channel	2	
20	8468	Right Roof Panel	2	
21	8469	Left Roof Panel	2	
22	8485	Left Side Roof Trim	2	
23	8840	Ridge Cap	1	
24	10470	Roof Beam	8	
25	8836	Right Side Roof Trim	2	
26	9922	Side Wall Channel	4	
27	8839	Side Wall Angle	4	
28	8486	Ridge Cap	1	
29	8934	Ramp	1	
30	9367	Front Floor Frame	2	
31	8936	Rear Floor Frame	2	
32	8937	Side Floor Frame	4	
33	8471	Corner Panel	4	

Assembly by Key No.

A13

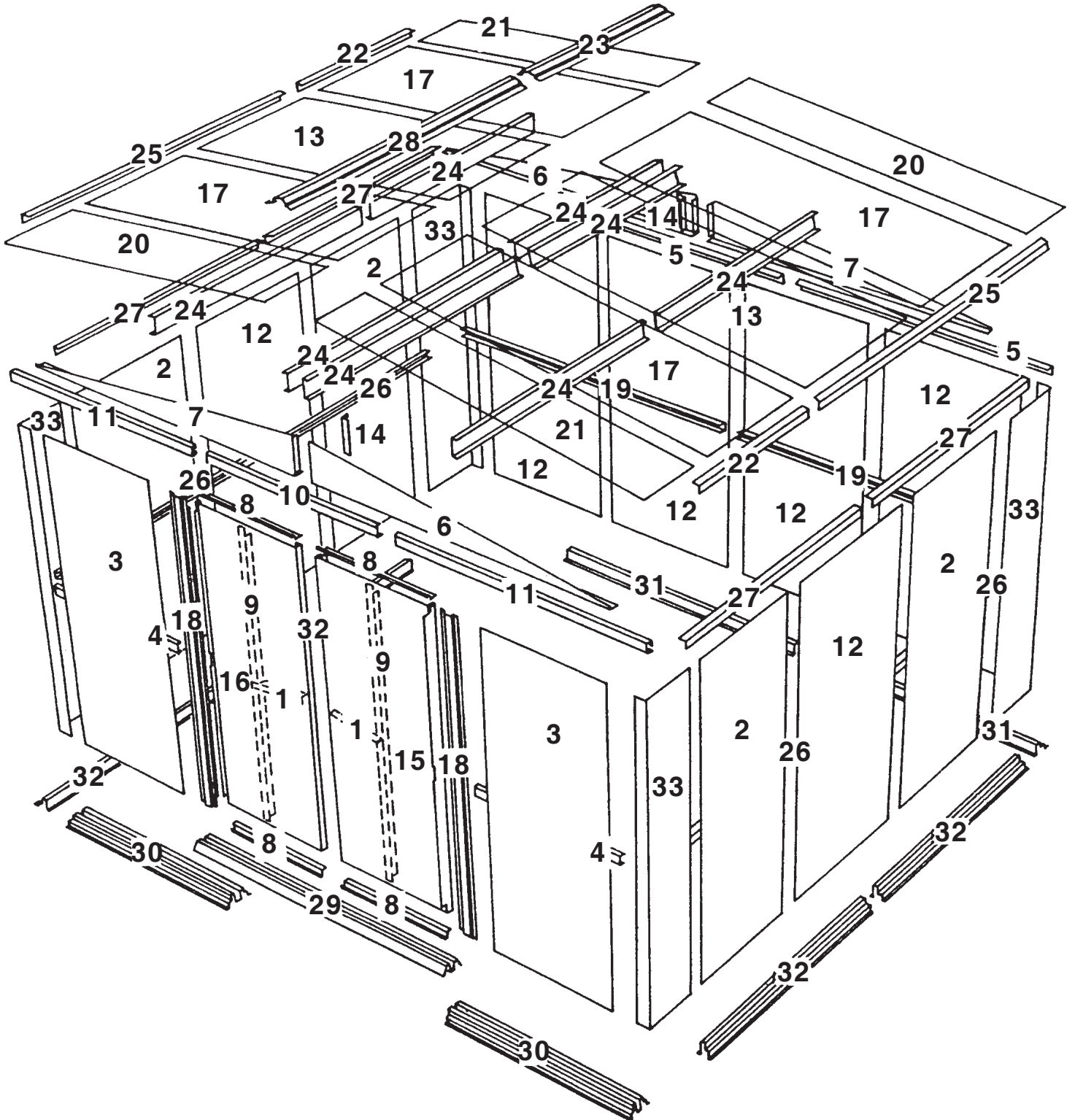

Step 1

A14

● Parts Needed For ● Floor Frame Assemblies

- 8934 Ramp (1)
- 9367 Front Floor Frame (2)
- 8936 Rear Floor Frame (2)
- 8937 Side Floor Frame (4)

The front floor frame is made up of three pieces. The side floor frames and the rear floor frame are made up of two pieces. The holes in these pieces will align when the pieces are positioned with correct amount of overlap. The illustrations below show the proper overall length for the sides, rear and front. Proceed as follows:

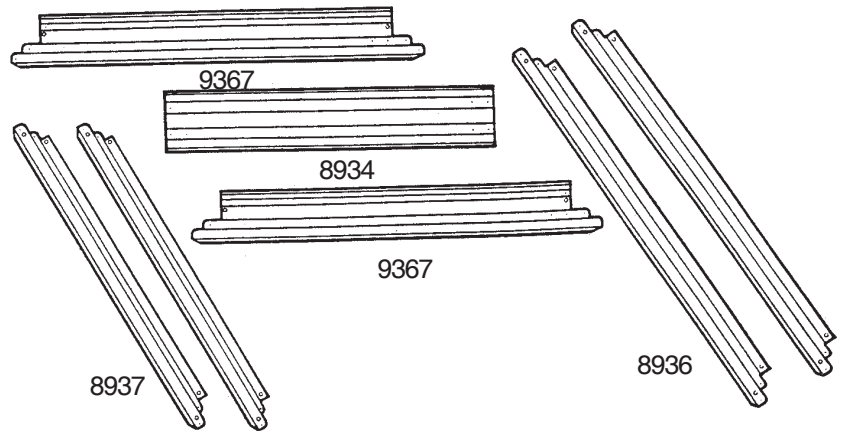

1 Place the **front floor frames** as shown. Center the **ramp**, with drain holes facing outside, on top of the two front floor frames. Join the frames by inserting eight screws.

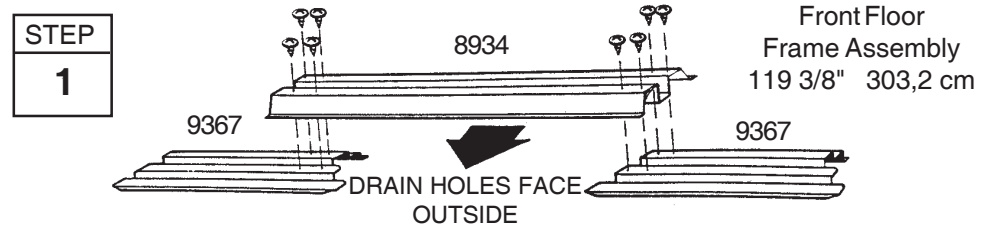

2 Overlap the **side floor frames** and the **rear floor frames** as shown. The holes in these pieces will align when the pieces are positioned with correct amount of overlap. See the illustrations below for the proper overall length of the side and rear floor frames. Join the frames by inserting four/five bolts into each frame set as shown.

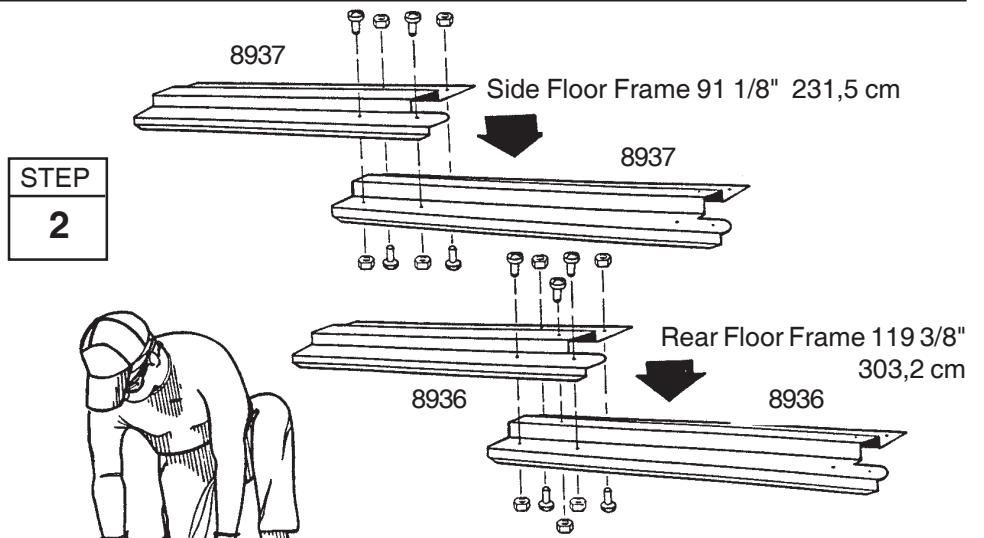

3 Double check the length of each and set these pieces aside for later use.

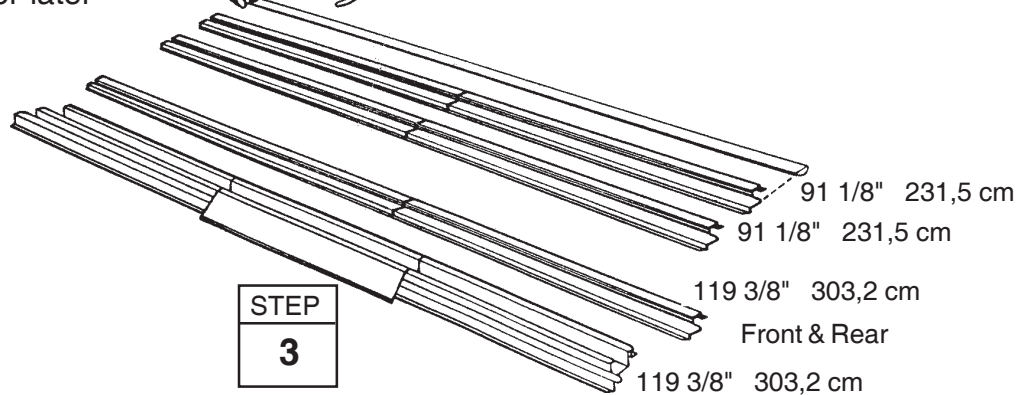

Step 2

A15

● Parts Needed For ● Frame Assemblies

- 5986 Rear Wall Angle (2)
- 9917 Rear Wall Channel (2)
- 9922 Side Wall Channel (4)
- 8839 Side Wall Angle (4)

The main frame pieces reinforce the walls. These pieces will later be installed in the center and at the top edge of the side walls and the rear wall. Proceed as follows:

1 Overlap the **rear wall channel** pieces as shown in the figure and fasten the two pieces together with *one bolt in the center hole* (three holes will align).

2 Make two **side wall channels** by overlapping the side wall channel pieces as shown. Fasten each set together with *one bolt in the center hole* of each set.

3 Overlap the **rear wall angle** pieces as shown in the figure and fasten them together with *one bolt in the center hole*.

4 Make two **side wall angles** by overlapping the side wall angle pieces as shown. Fasten each set together with *one bolt in the center hole*.

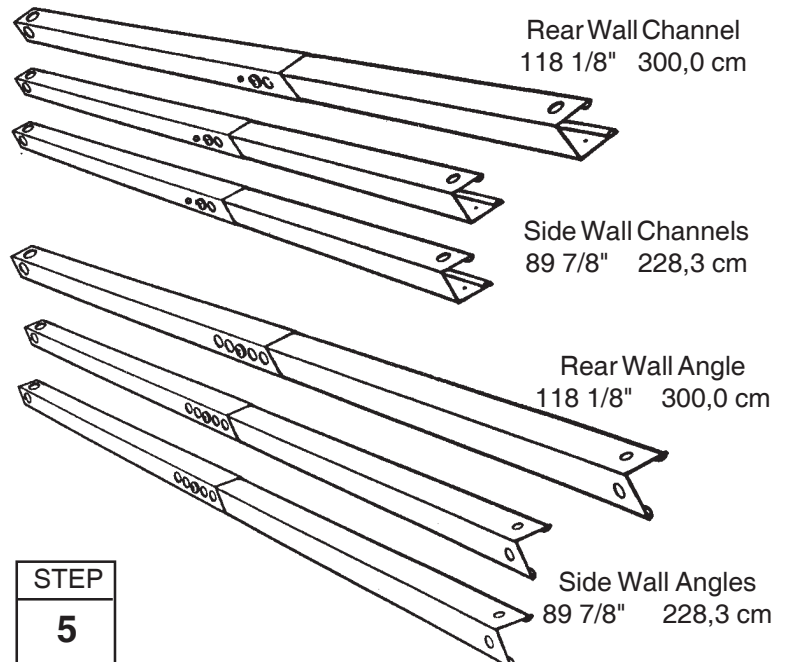
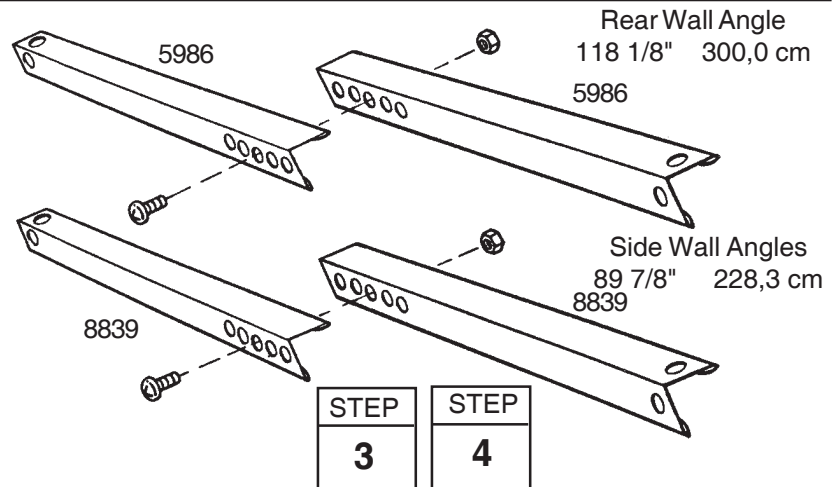
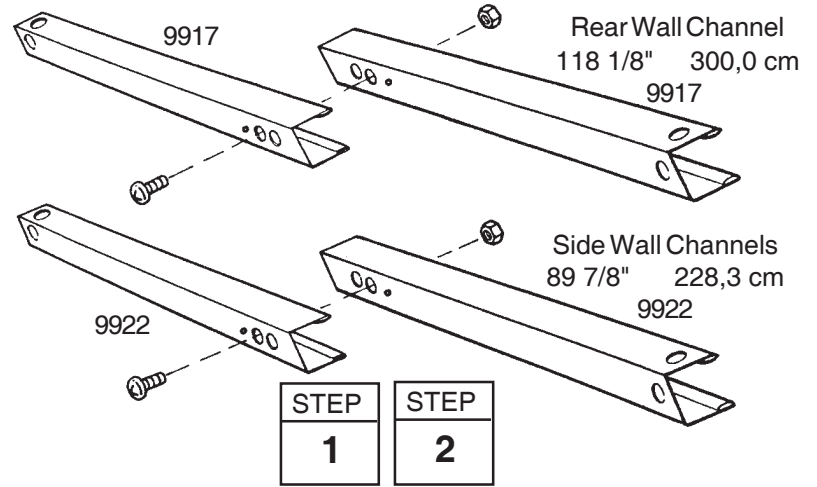

5 Set the assemblies aside. You will use them later.

Step 3

D16

● Parts Needed For ● Roof Beam Assemblies

● 10470 Roof Beam (8)

The roof beams join the two gables and support the roof panels. The main roof beam is made up of four pieces overlapped back to back at the center. The left and right roof beam assemblies are made up of two pieces. **Hint:** These pieces are force-fitted, so you may have to press hard to join them together.

1 Place the end of one roof beam inside a second roof beam so that the six holes in each piece align. Make four sets of roof beams by repeating this procedure. ***Do not insert bolts yet.***

2 Take two of the pressed-together roof beams and join them as shown to form the main roof beam assembly. Hold the assembly together and fasten with 14 bolts. Build ***only one*** Doubled Beam Assembly.

3 Fasten the other two pressed-together roof beams with eight bolts to make the left and right roof beam assemblies.

4 Set these pieces aside for later assembly.

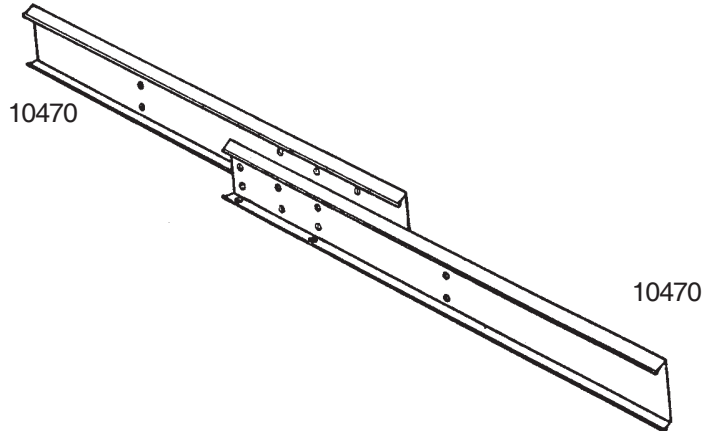

STEP
1

Roof Beam 91 7/8" 233,4 cm

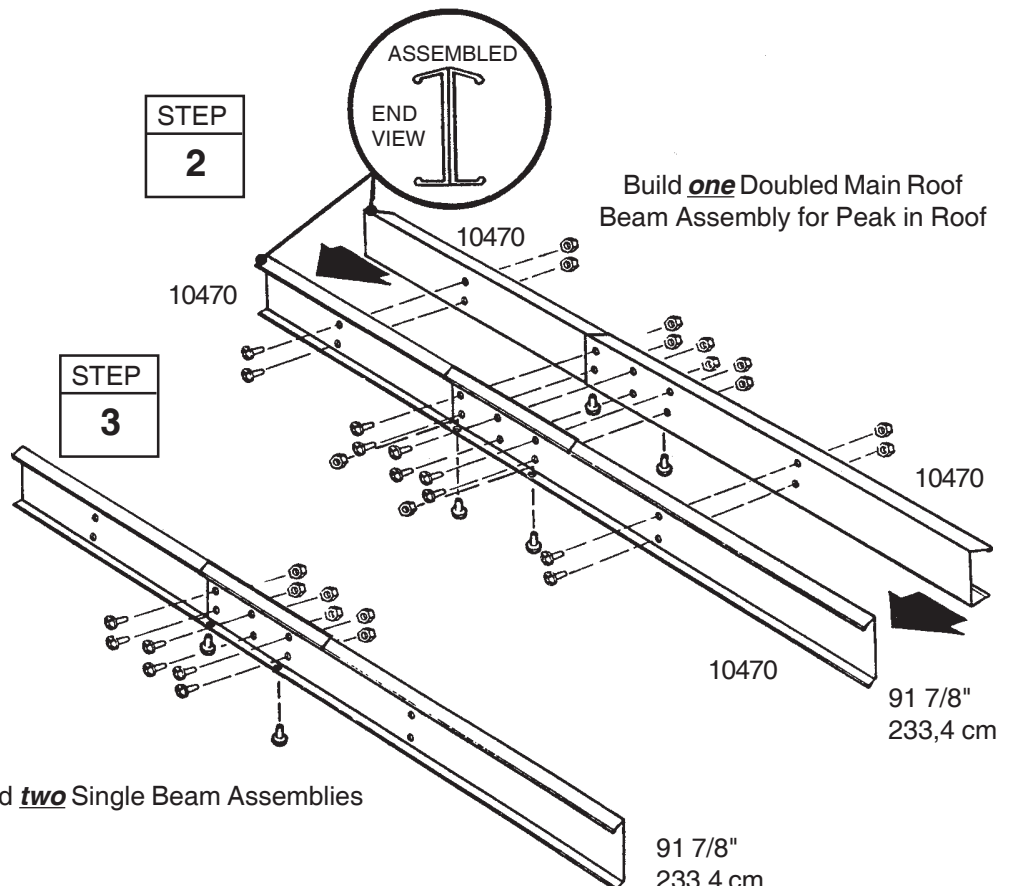
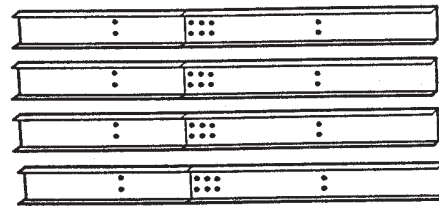

Step 4

A17

● Parts Needed For ● Door Track Assembly

- 6403 Door Track Splice (1)
- 9366 Door Track (2)

The door track assembly supports the sliding doors and reinforces the front wall. It is made up of three pieces.

1 Using the **door track splice**, (painted), join the **door track** (galvanized) pieces end-to-end as shown.

2 Insert four screws *from the underside only*.

Hint: The holes in the top side of the door track assembly are for fastening the gable to the top of the front wall in a later step.

3 Position **door slides** onto the legs, from the end of door track assembly, as shown in the end view.

4 Set this piece aside for later use.

NOTE:
Door Track Splice (painted part)

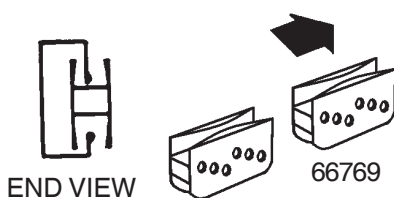
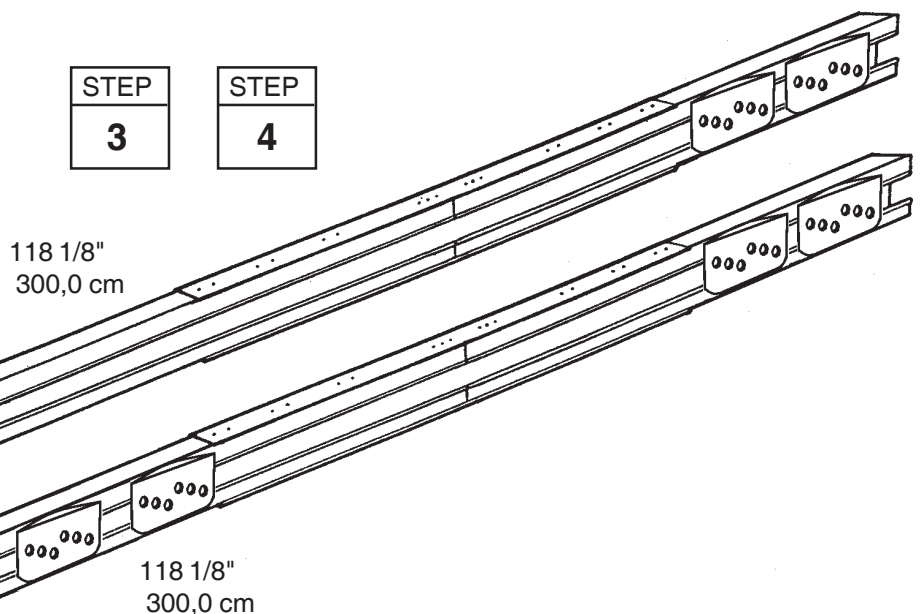
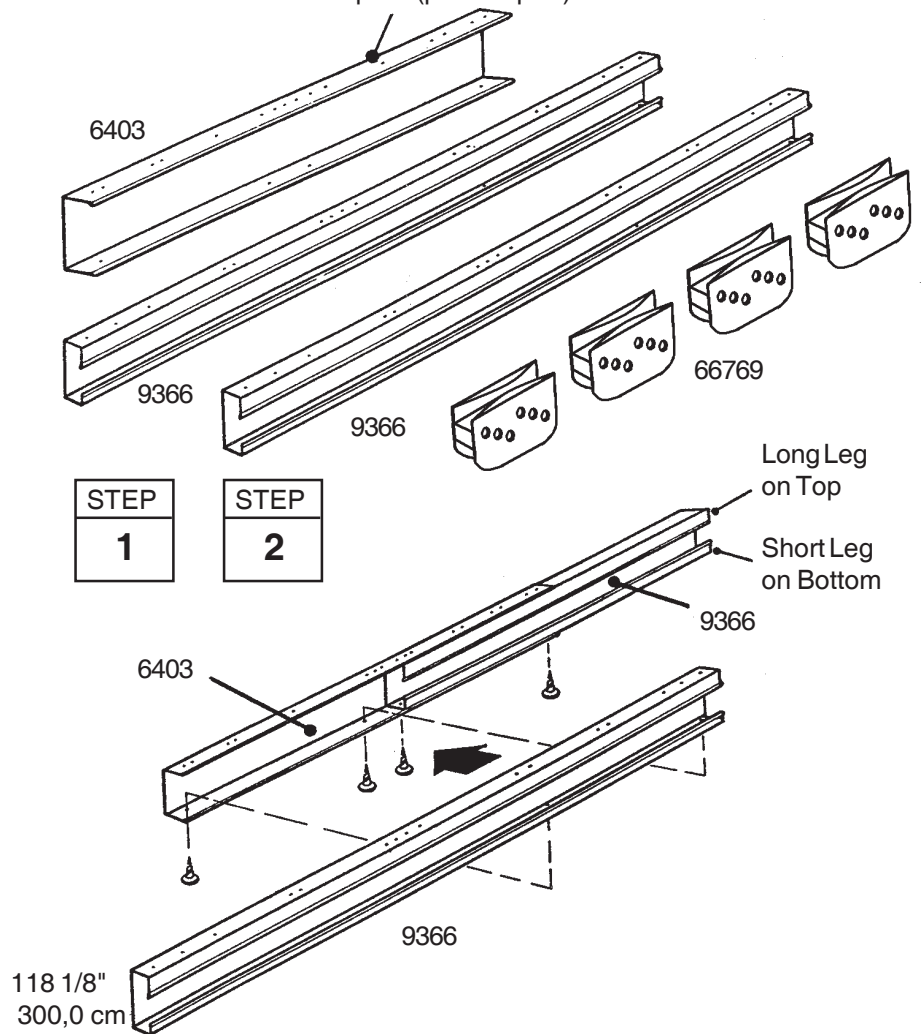

Step 5

A18

● Parts Needed For ● Floor Frame

- Front Floor Assembly (1)
- Side Floor Assembly (2)
- Rear Floor Assembly (1)

1 Assemble the four corners of the floor frame using two screws at each corner as shown. At the front corners fasten bolts through from the bottom with nuts on top.

STEP
1

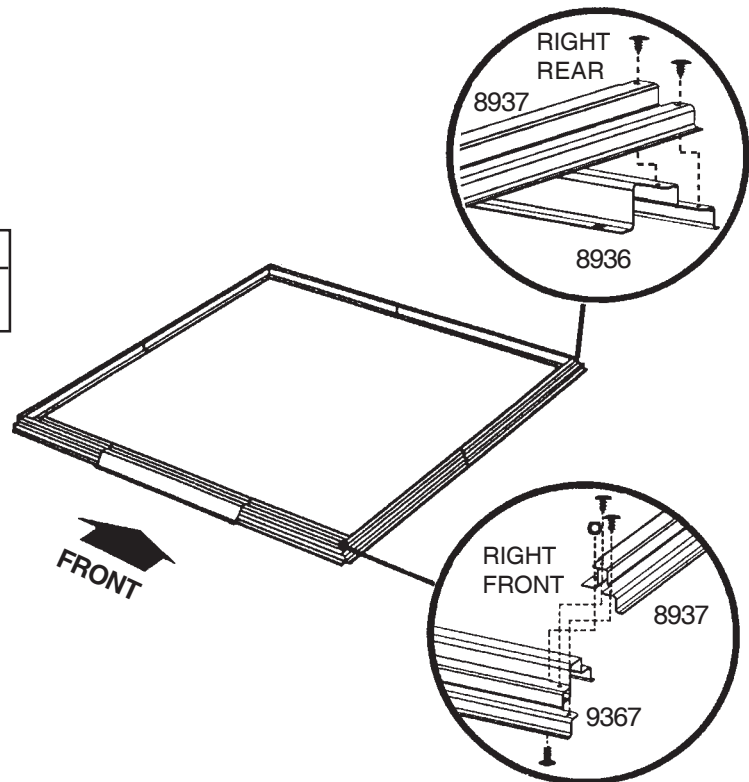

2 Measure the floor frame diagonally. When the diagonal measurements are equal, the floor frame is square.

When Diagonal Measurements are Equal the Floor Frame is Square.

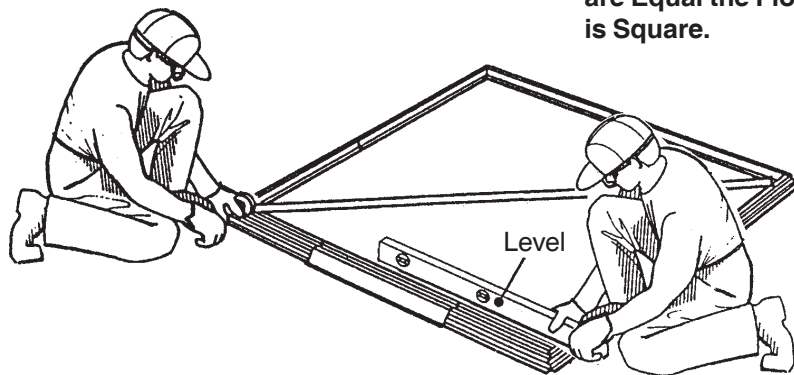

STEP
2

NOTE

If using a wood platform or concrete slab do not fasten the floor frames to your base at this time. You will anchor the building after it is erected.

NOTE

If you have purchased a Floor Frame Kit you need to install it at this time.

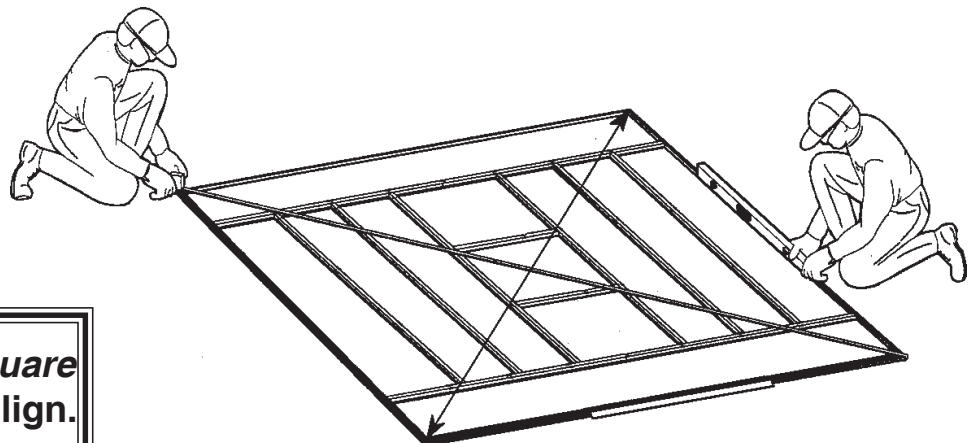

The floor frame *must be square and level* or holes will not align.

Step 6

U19

● Parts Needed For ● Corners

- 6627 Wall Panel (2)
- 9374 Front Wall Panel (2)
- 8471 Corner Panel (4)

NOTE

The remainder of the building assembly requires many hours and more than one person. Do not continue beyond this point if you do not have enough time to complete the assembly today. A partially assembled building can be severely damaged by light winds.

Each screw and bolt in the wall requires a washer.

1 Position a **corner panel** at the corner of the floor frame as shown. The widest part of each corner panel must be placed along the side of the building for all four corners. Fasten the corner panel to the floor frame with one screw.

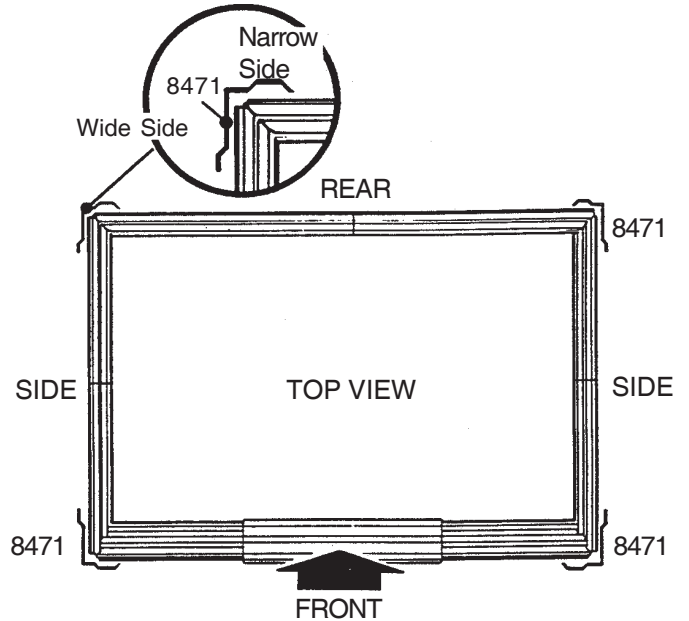

STEP
1

Support the corner panel with a step ladder until a wall panel is attached.

2 Attach the **front wall panels** to the front corner panels, as shown. A small gap will exist between front wall panel and ramp.

3 Attach the **wall panels** to the rear corner panels, as shown.

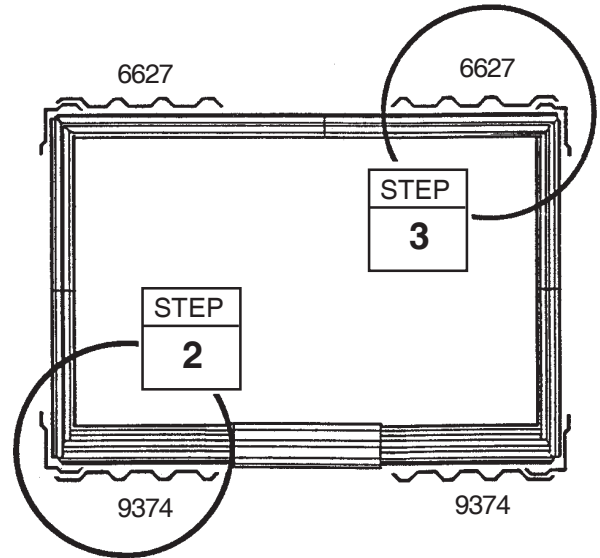

STEP
2

STEP
3

NOTE

Be careful to install the correct panel in each position as shown

4 Double-check the part numbers of the wall panels, before proceeding.

The floor frame *must be square and level* or holes will not align.

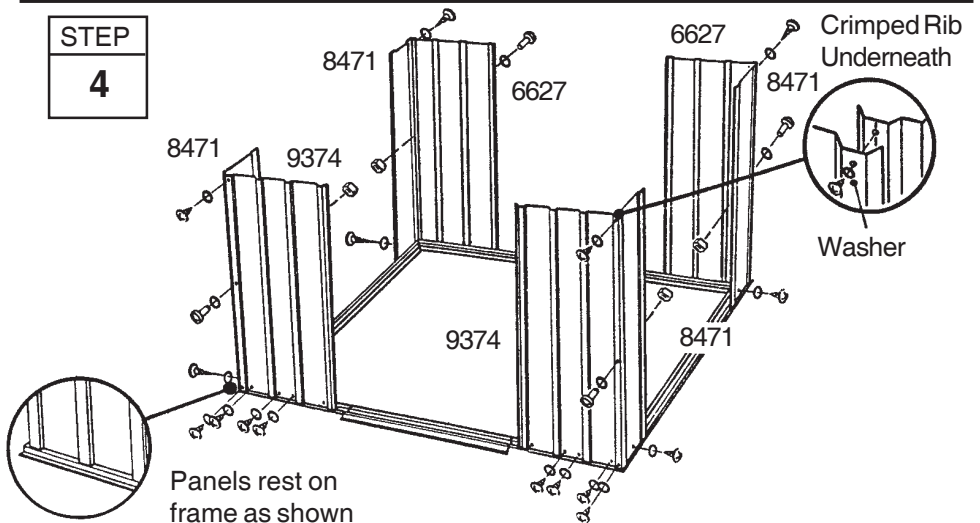

STEP
4

Panels rest on frame as shown

Step 7

A20

● Parts Needed For ● Frames

- Door Track Assembly (1)
- Rear Wall Angle Assembly (1)
- Side Wall Angle Assemblies (2)
- Rear Wall Channel Assembly (1)
- Side Wall Channel Assemblies (2)

The main frame pieces give rigidity to the side walls and provide a surface for attaching the gables which support the roof.

1 Fasten the **rear wall angle assembly** across the inside top of the rear wall using screws.

2 Fasten the **rear wall channel assembly** across the middle of the rear wall using screws.

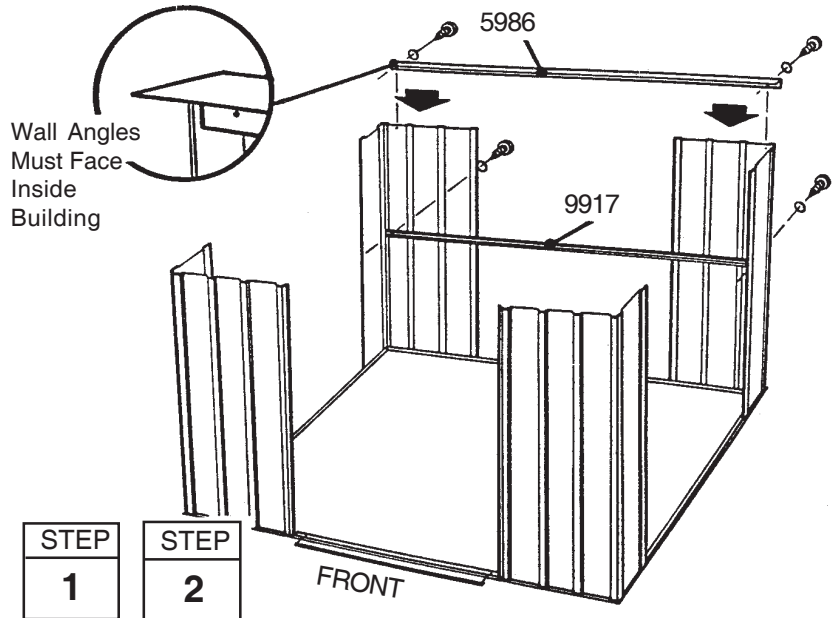

3 Fasten the **side wall angles** across the inside top of the side panels using screws. Side wall angles must overlap rear wall angle in corners.

4 Fasten the **side wall channel assemblies** across the middle of the side panels using screws. Fasten overlaps in rear corners with screws.

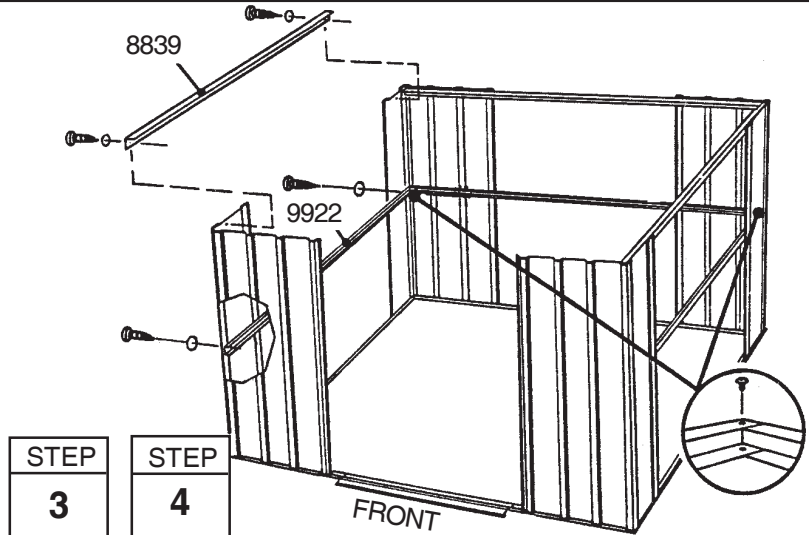

5 Fasten the **door track assembly** (holes on top) across the top of the front wall panels using screws. See the figure.

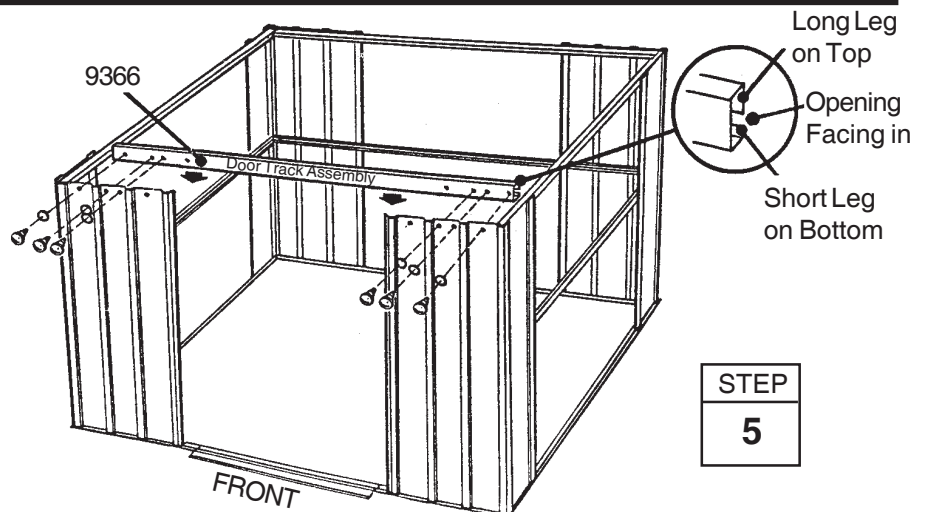

NOTE

The wall channels behind the front wall panels will be installed in a later step.

Step 8

V21

● Parts Needed For ● Wall Panels

- 8200 Wall Panel (4)
- 6627 Wall Panel (4)

The wall panels come in two widths. Each wall panel has a crimped rib on one side. The crimped rib should go under the rib of the panel that follows it.

1 Locate all of the **wall panels** and set each one alongside the building.

2 Be sure that you have the correct panels in each position. Do this by overlapping the panels and determining if the holes line up with the holes in the frame.

3 Fasten the wall panels at the top and bottom with screws.

4 Fasten the center of each panel to the wall channel with screws. Fasten overlapping ribs as before.

5 When you have attached all wall panels in the correct positions, the building will look like this.

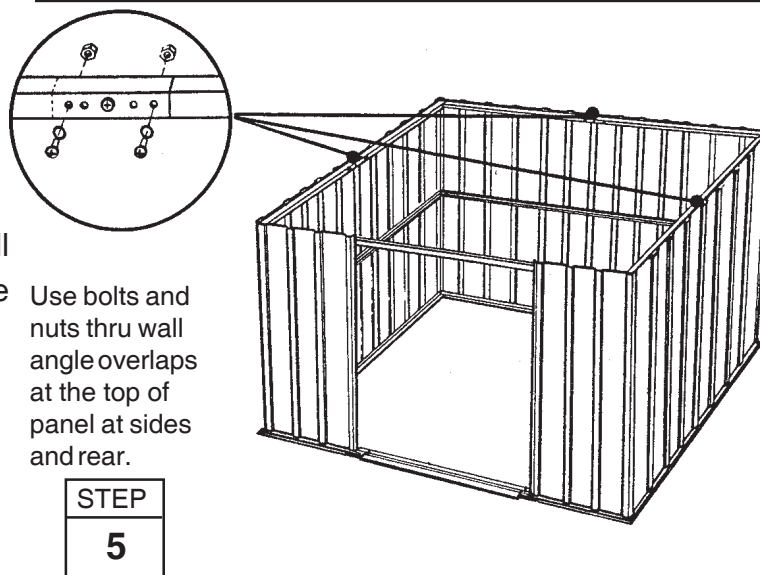
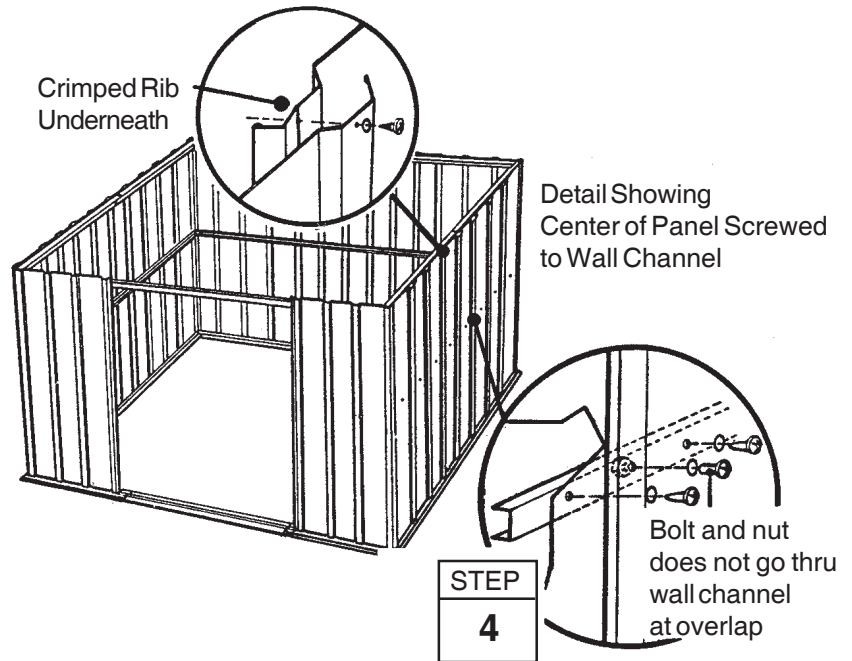
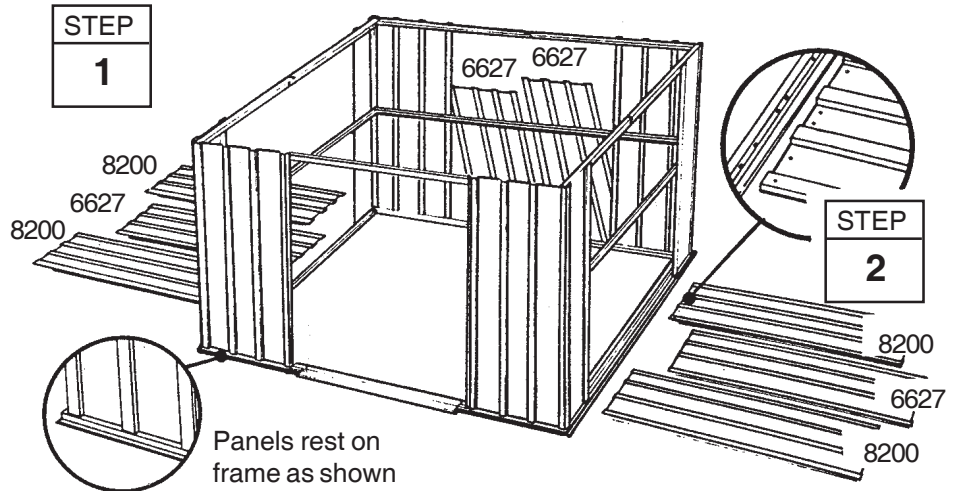

Step 9

U22

● Parts Needed For ● Front Channel/Door Jamb

- 9370 Door Jamb (2)
- 9365 Front Wall Channel (2)

The door jambs reinforce the door opening and provide an attractive trim. Follow these steps for both door jambs.

1 Fasten the **front wall channels** in their positions between the end of the side wall channel and the corner panel using screws. Do not put a screw in the hole at the end behind the door opening at this time.

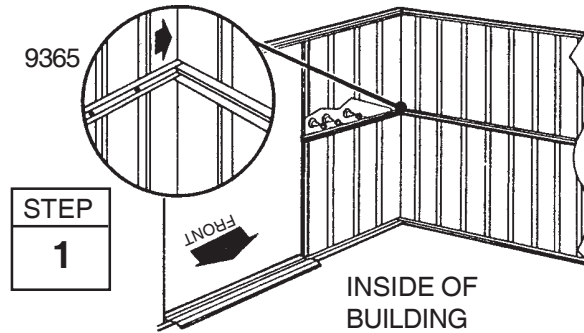

2 Fasten a **door jamb** to the front panel with two bolts, nuts and acorn nuts, as shown.

3 Fasten the center of the door jamb to the front wall panel and the front wall channel with two screws.

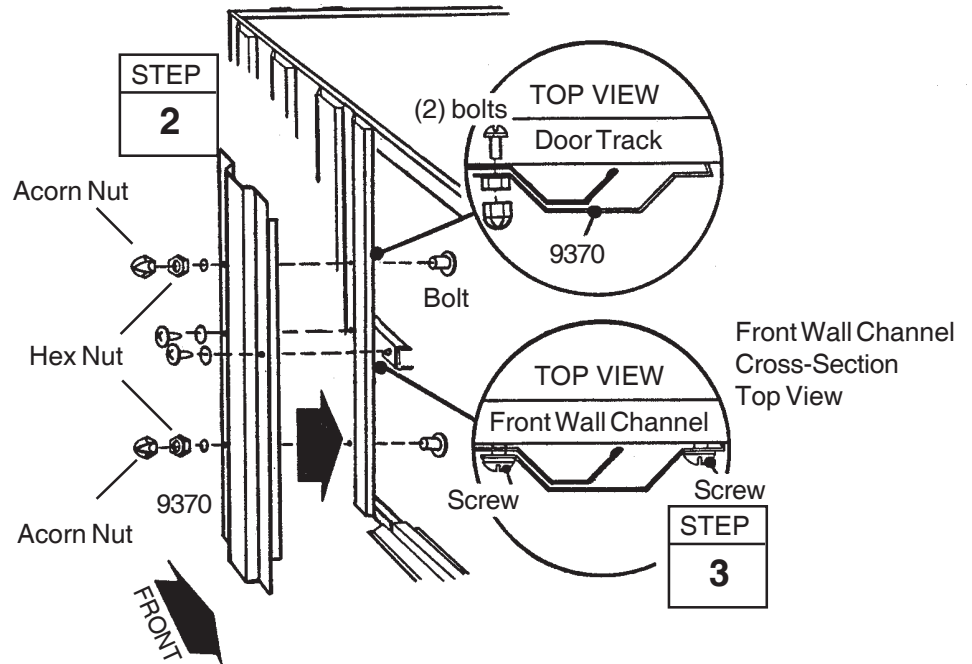

4 Fasten the top of the door jamb to the door track with two screws. Do the same for the bottom into frame.

Repeat steps 2 through 4 for the *opposite* door jamb.

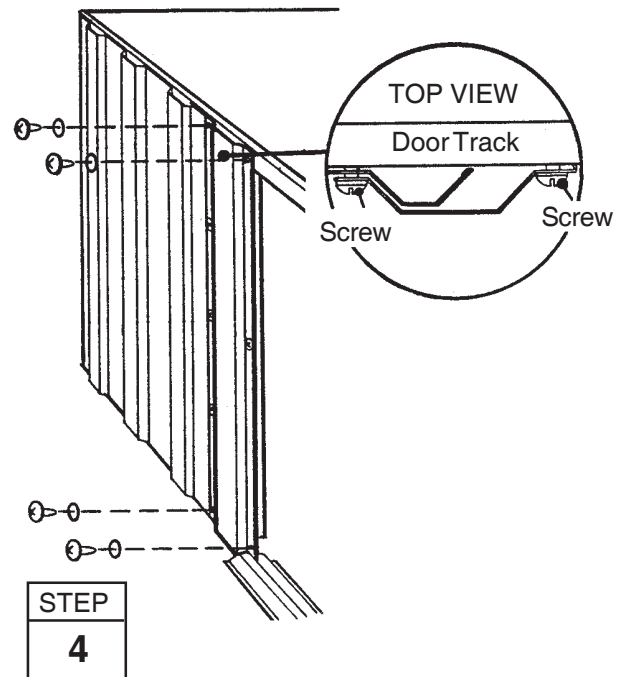

Step 10

A23

● Parts Needed For ● Gable Assemblies

- 6000 Right Gable (2)
- 6001 Left Gable (2)
- 5971 Roof Beam Bracket (4)

The gables go on top of the front and rear walls to support the roof beams.

NOTE

The gables are packed nested together and might be mistaken as one piece. Carefully separate them before continuing.

1 Attach the four **roof beam brackets** to the gables using two bolts, washers and nuts.

NOTE

Mounting leg of bracket must face toward center of gable and holes closest together must be on top

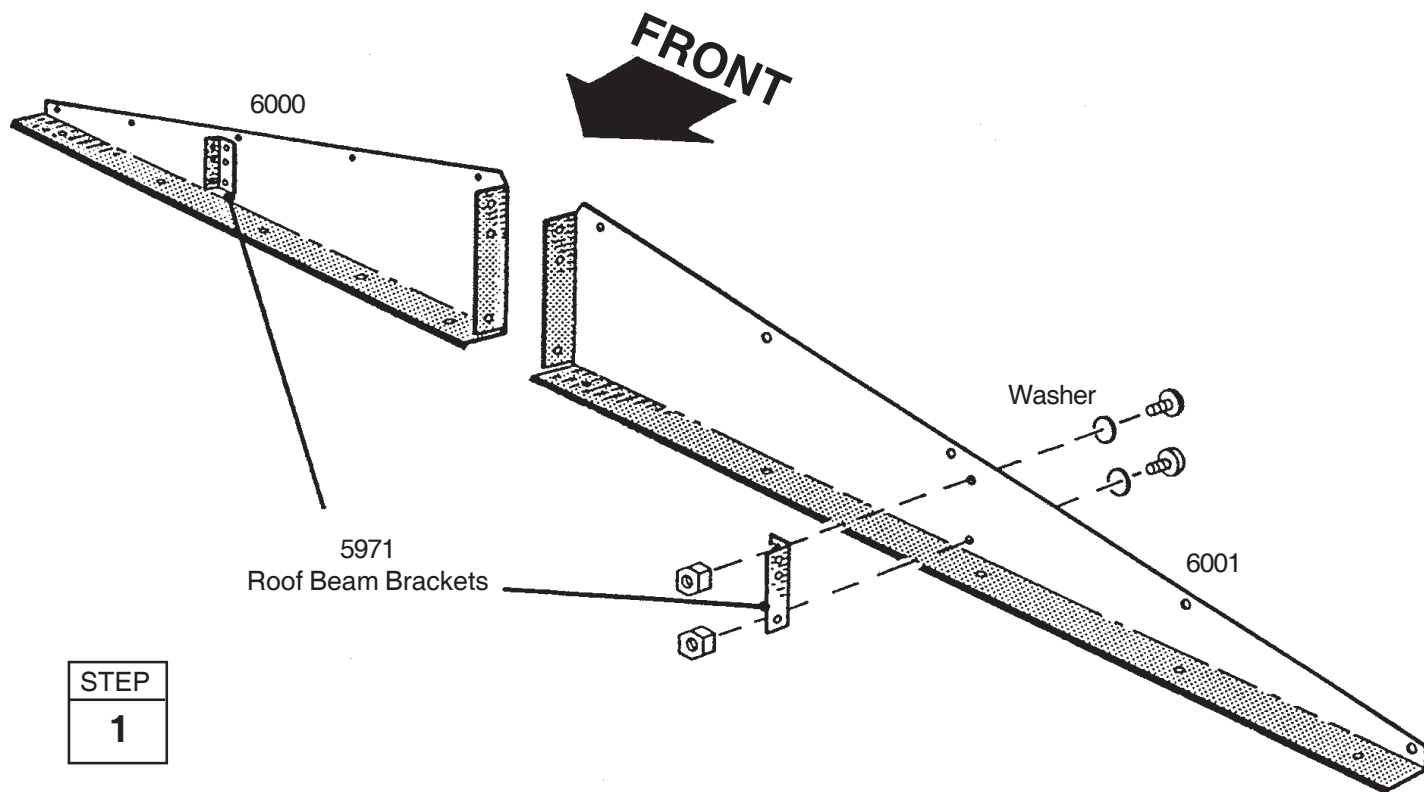

STEP

1

Step 11

A24

● Parts Needed For ● Gables/Braces

- Left Gable Assemblies (2)
- Right Gable Assemblies (2)
- 6635 Gable Brace (2)

1 Lift and fasten a right and left gable, under angle at corner, to the door track and rear wall angle with screws.

Hint: On the rear gable, use a bolt and nut at the overlapping rear wall angle. On the front gable, leave out 2 screws closest to center gable leg.

2 Join the **left** and **right gables** together with a **gable brace** using a bolt and nut in the bottom hole *only*.

3 Repeat Steps 1 & 2 for the door track on the front of building, except for the **track supports**, fasten as shown.

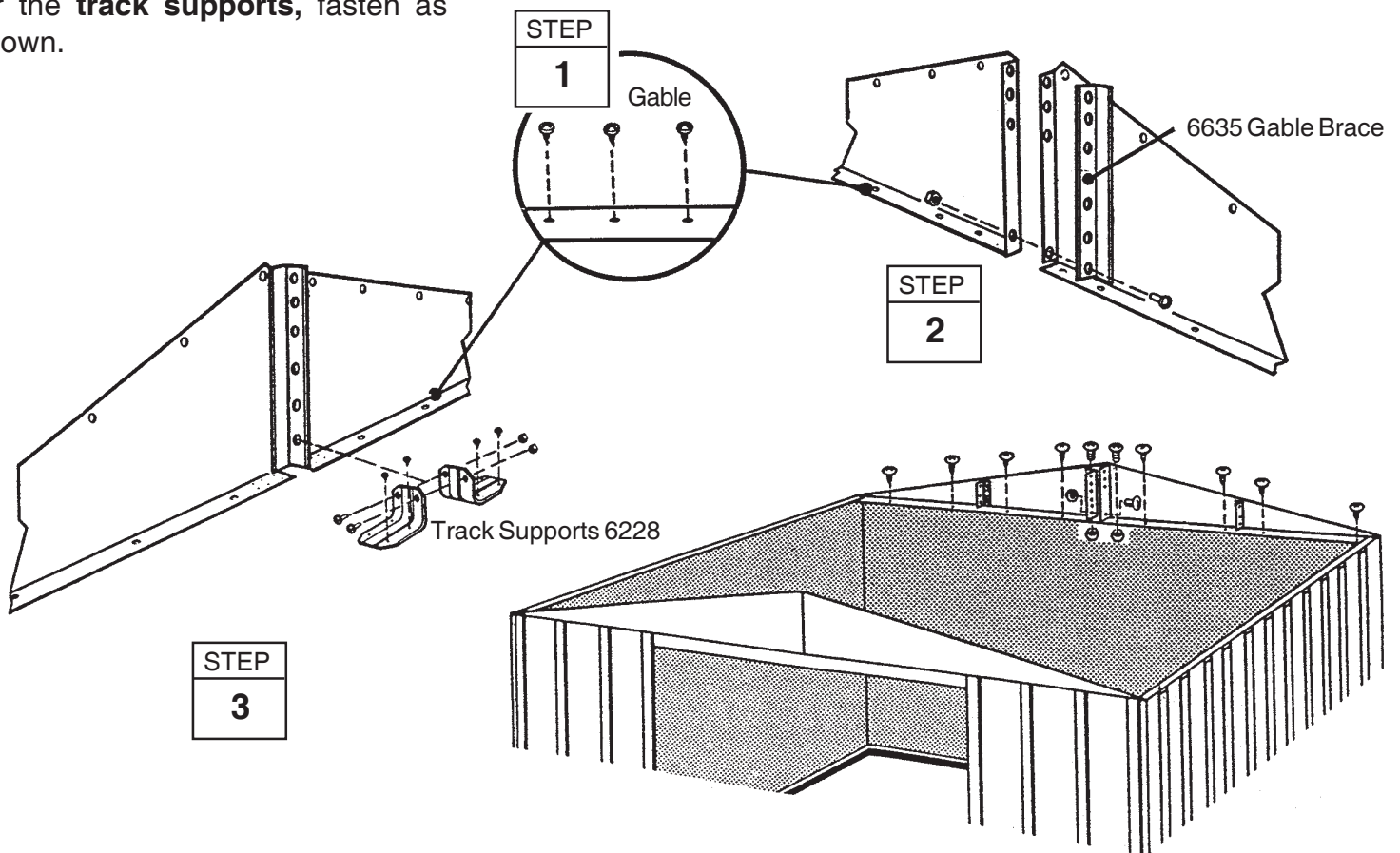
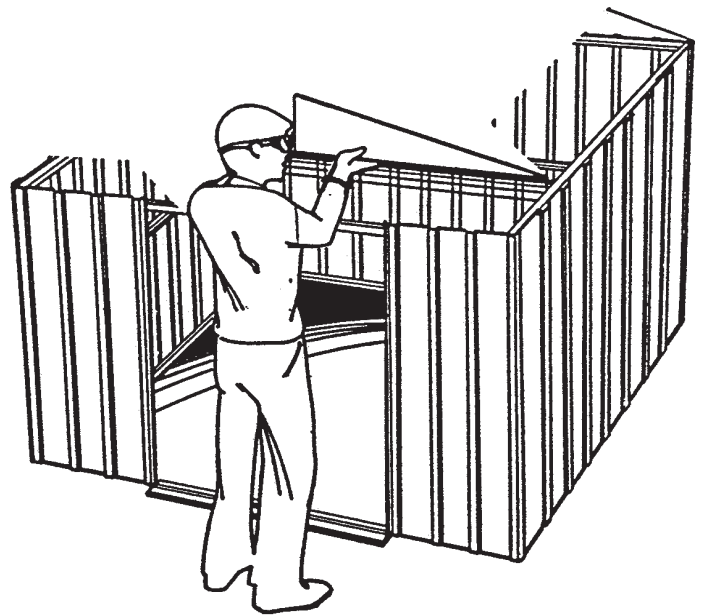

Step 12

A25

● Parts Needed For ● Roof Beams

- Main Roof Beam (1)
- Single Roof Beam (2)

1 Spread the two halves of the **main roof beam** and fasten the roof beam to the gable brace of the front gable.

2 Fasten the other end of the main roof beam to the gable brace of the rear gable.

3 Fasten the **single roof beams**, *small holes on top*, as shown using bolts and nuts.

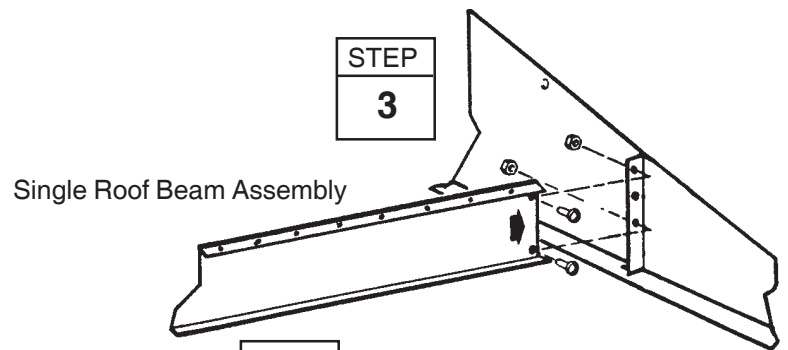

Single Roof Beam Assembly

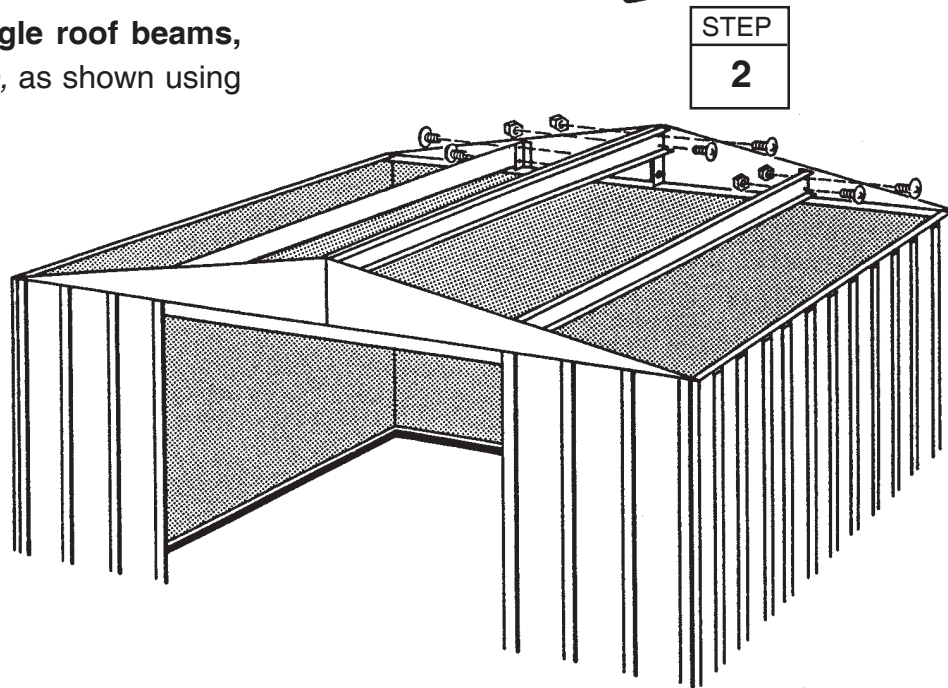

Spread Two Halves
Of Roof Beams

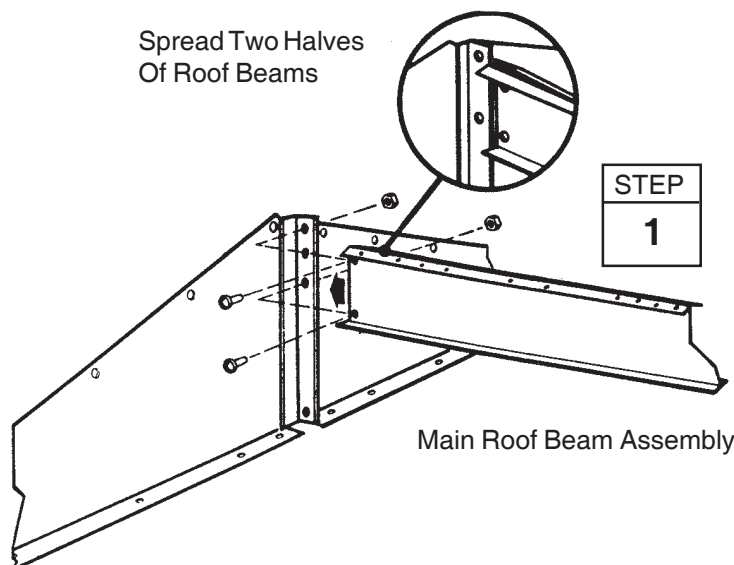

Main Roof Beam Assembly

Step 13

A26

● Parts Needed For ● Right Roof Panel

● 8468 Right Roof Panel (1)

Installing the roof panels is best done with a step ladder. Begin installing roof panels at the back right corner of the building. Each screw and bolt in the roof requires a washer.

NOTE

Measure the building diagonally again and make adjustments to make sure the building is square. This will make the roof panels fit better, and holes will align.

NOTE

If a **Roof Beef-Up Kit** was purchased, assemble prior to attaching the roof panels.

1 Locate the roof panels by their numbers. *Note the sequence and position they are to be installed.*

2 Position the **right roof panel** at the back right corner and fasten to the gable with 5 bolts and nuts and roof beams using 2 screws. *Do not fasten the lower end of the panel to the side wall angle at this time.*

Hint: Attach fasteners in order shown in diagram.

STEP

1

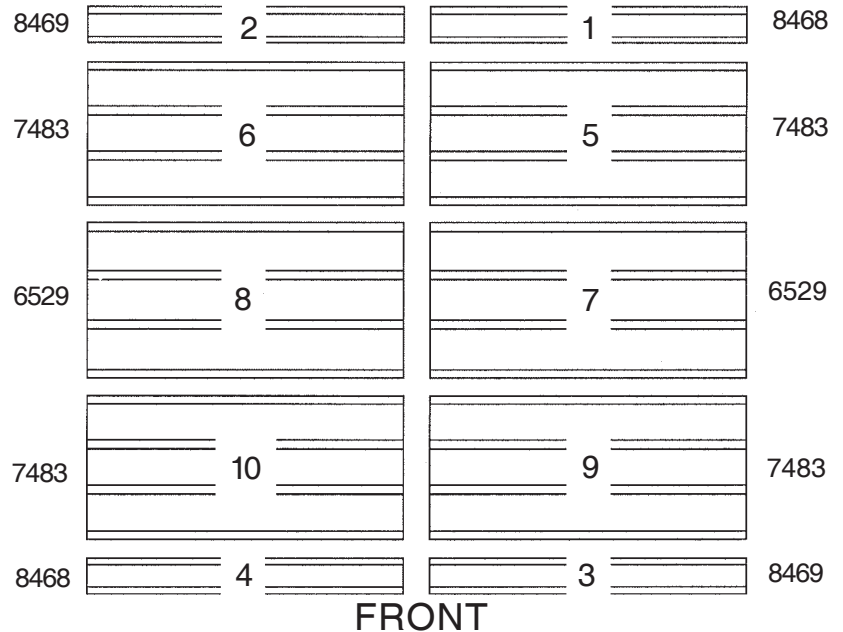

STEP

2

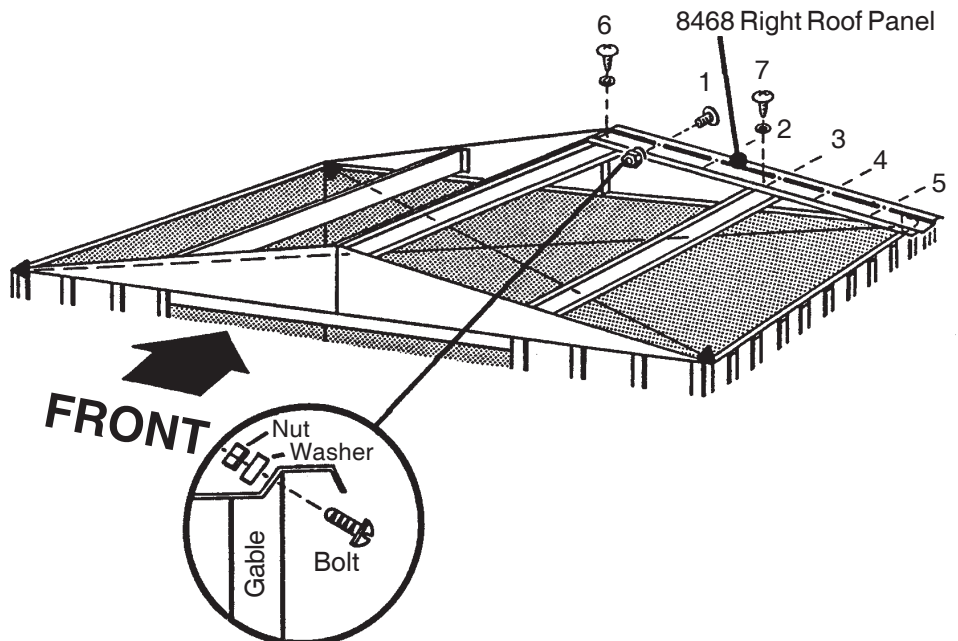

Step 14

A27

● Parts Needed For ● Roof Assembly

- 8468 Right Roof Panel (1)
- 8469 Left Roof Panel (2)
- 7483 Roof Panel (2)
- 6529 Roof Panel (2)

1 Install a **left roof panel** at the left rear and right front corner of the roof. Install a **right roof panel** at the left front corner of the roof.

2 Cut 4 short 2" (5,1 cm) strips off the roll of **weather stripping tape**, and put them aside. Cover the joint at the peak with weather stripping tape. Unroll the tape and press it down over the opening at the ridge as you install each roof panel. Do not cut the tape at this time.

3 Install 2 **narrow** and 2 **wide roof panels** in the sequence and positions shown on previous page. *Do not fasten the lower end of the panels to the side wall angles at this time.* Continue weather stripping the ridge opening.

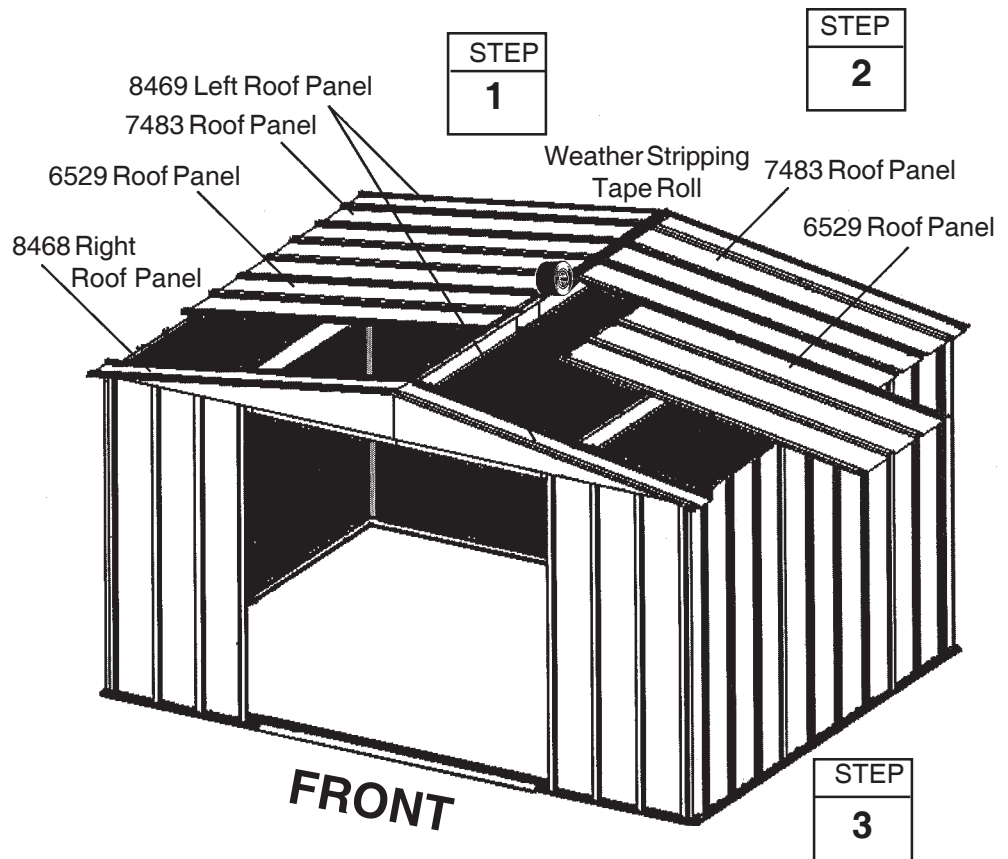

NOTE

Narrow roof panel crimped rib is overlapped by wide rib of adjacent panel where possible.

NOTE

If roof beam holes do not line up with the roof panel holes, shift the building from left to right. If this does not help, your building may not be level. Shim the corners until holes line up.

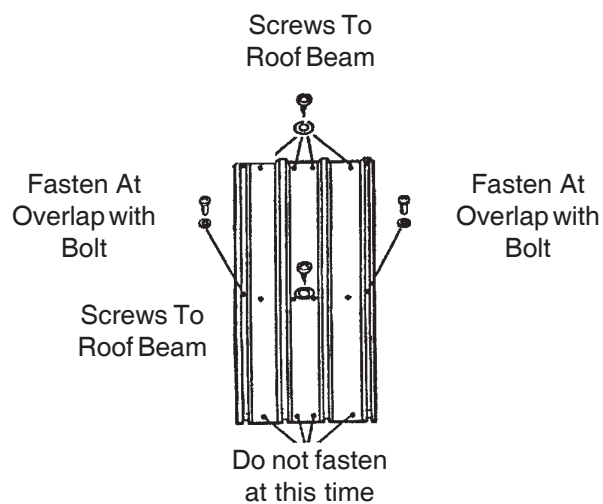

Step 15

A28

● Parts Needed For ● Ridge Caps & Panels

- 8840 Ridge Cap (1)
- 7483 Roof Panel (2)
- 8486 Ridge Cap (1)

1 Install the first **ridge cap** on the completed roof section using bolts and nuts. Fasten roof panel overlaps not used for ridge cap. Cover the head of bolt with the 2" (5,1 cm) piece of weather stripping tape. Do not fasten the ends of the ridge cap at this time.

2 Install the second **ridge cap** overlapping the first ridge cap while installing the remaining narrow **roof panels**. Continue weather stripping the ridge.

3 Fasten the lower end of the panels to the side wall angles using screws and washers. Use bolts and nuts through wall angle overlaps at the bottom of the panel.

STEP
1

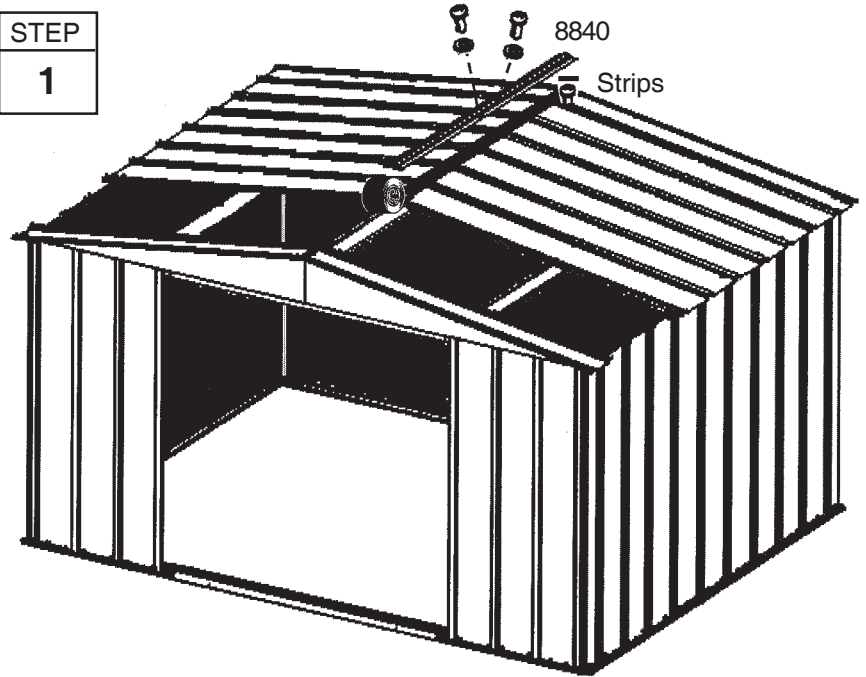

Cut Weather Stripping and Fold Under

8486

STEP
2

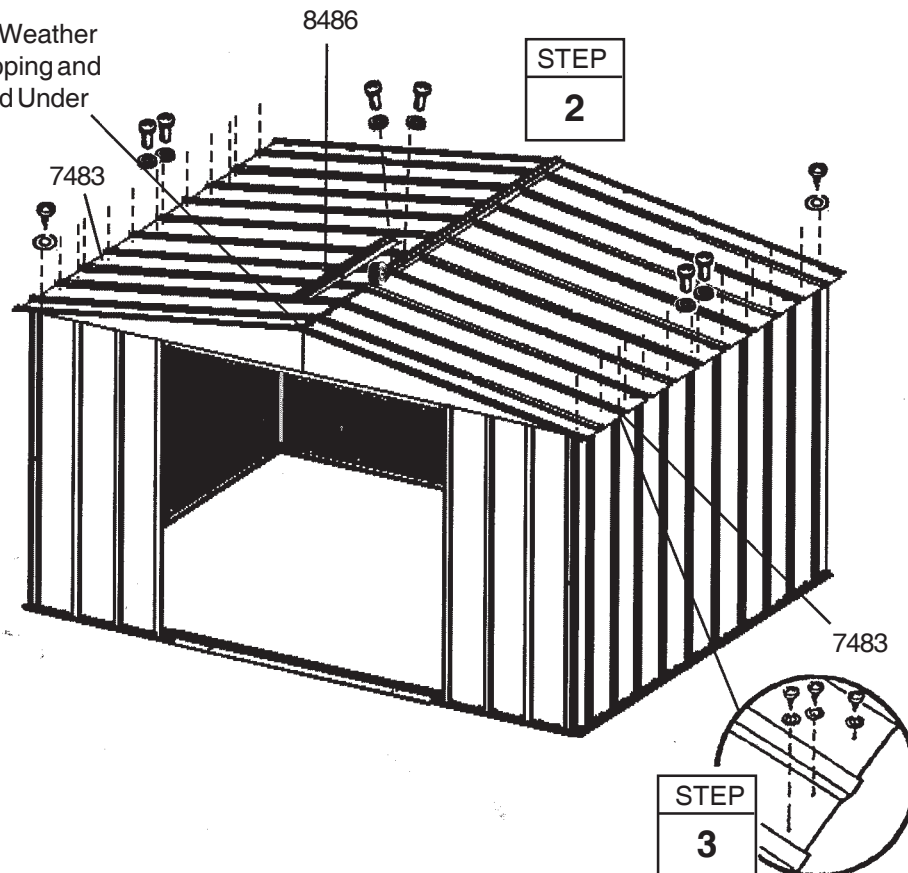

STEP
3

Step 16

A29

● Parts Needed For ● Roof Trim

- 8485 Left Side Roof Trim (2)
- 8836 Right Side Roof Trim (2)

1 Attach the **right** and **left side roof trim** to the lower end of the roof panels on each side of the building using screws at each panel overlap.

NOTE

A single screw fastens both trim pieces at the overlap.

2 Using your thumb and index finger, overbend the bottom flange of the side roof trim at the corner inward enough so the right and left roof trim caps fit onto right and left corners.

3 Fasten the roof trim caps to the side trim using a screw.

4 Fasten the roof panel ribs, **peak caps** and ridge caps together using bolts and nuts.

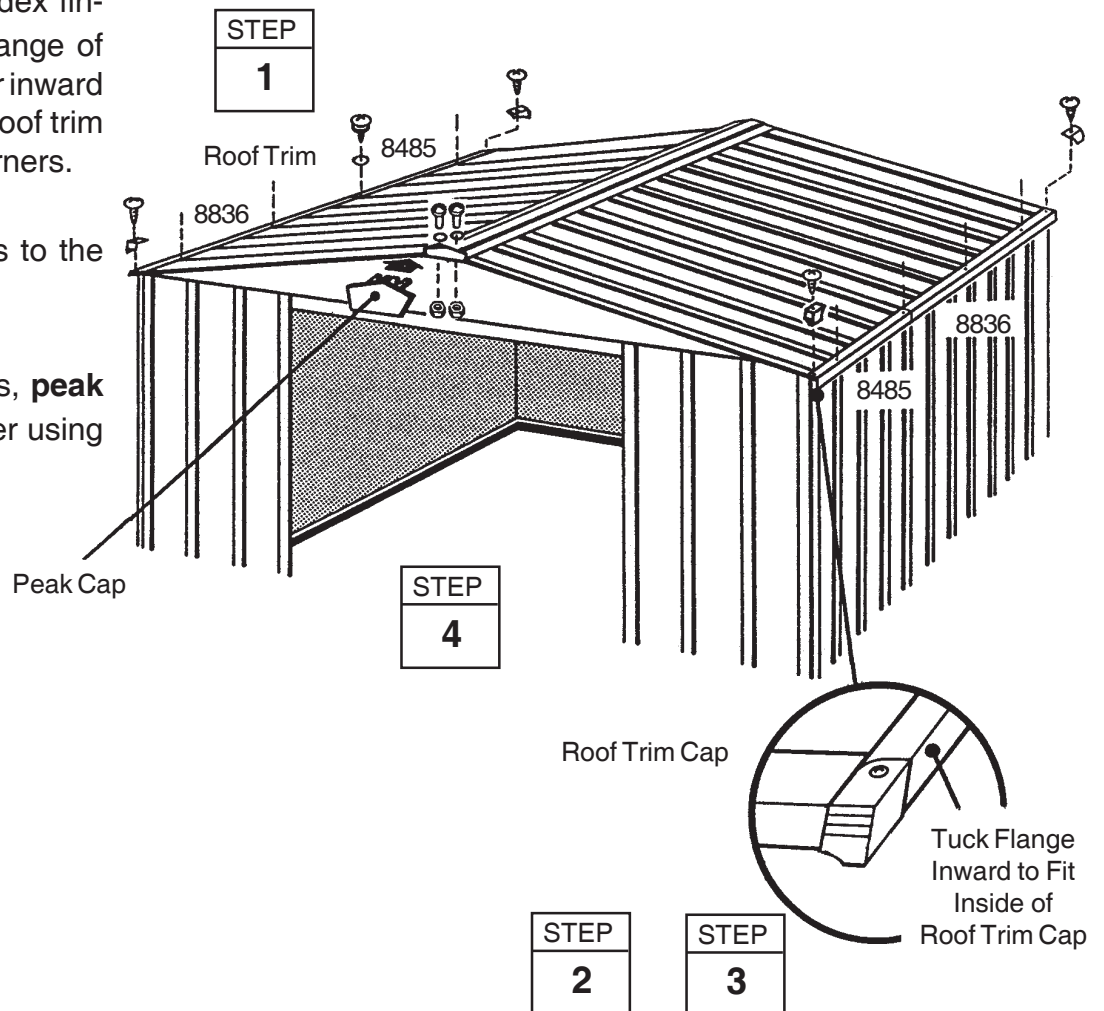

Step 17

U30

● Parts Needed For ● Door Assembly

- 3719 Door Handle Brace (2)
- 10477 Right and Left Doors (2)
- 10497 Horizontal Door Brace (4)
- 6300 Vertical Door Brace (2)

The steps on this page tell how to assemble the right door. You will perform exactly the same procedures for the left door. Each bolt and screw in the door requires a washer. Proceed as follows:

1 Attach the **door handle brace** and **handle** to the **door** with 1 bolt as shown. *Don't tighten the bolt yet.*

2 Swing the door handle brace up to the hole in the center of the door and insert a screw.

3 Hold the **vertical door brace** against the center of the inside surface of the door and turn the screw to hold the vertical door brace and door handle brace in place. Fasten to door above and below center connection using 2 screws.

4 Insert a second bolt in the door handle and tighten both bolts.

5 Put a **horizontal door brace** onto the top edge and bottom edge and fasten *with 1 bolt in the center.*

6 Attach the **lower door guides and bolts** as shown.

7 Repeat steps 1 through 6 for the **left door.**

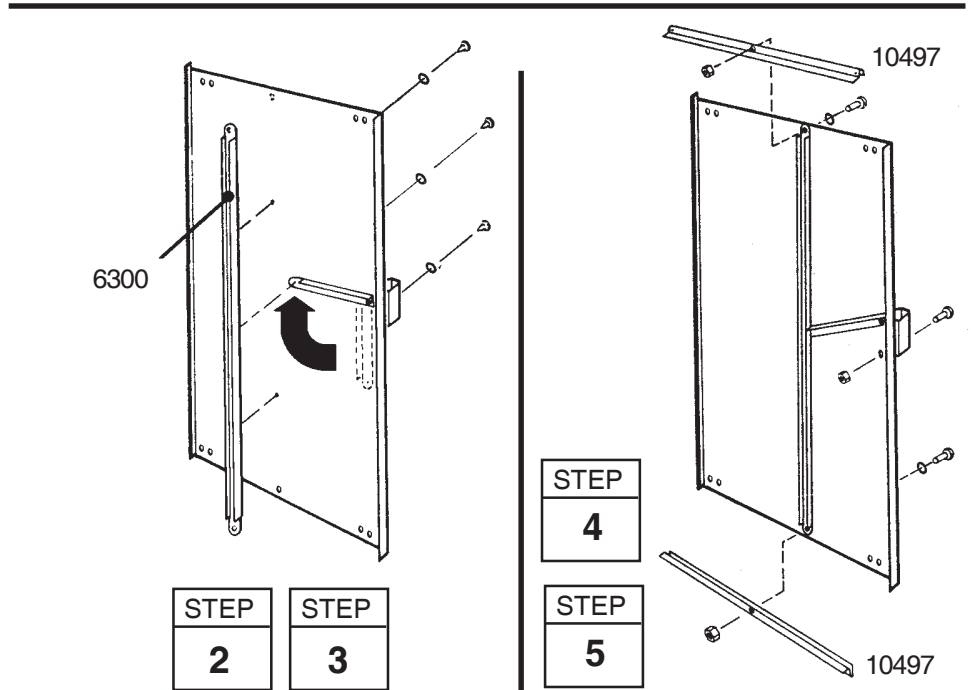
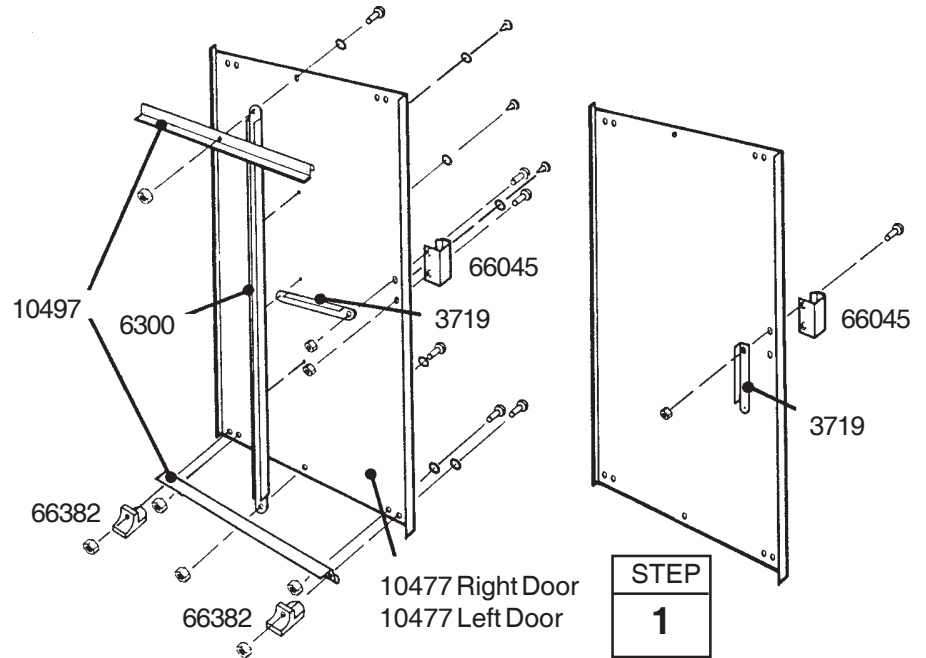

END VIEW
SHOWING:

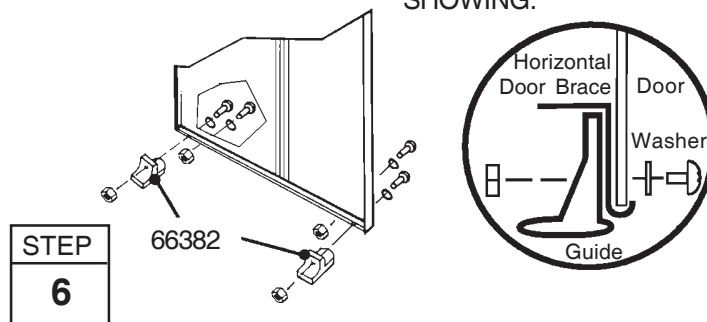

Step 18

A31

● Parts Needed For ● Door Installation & Adjustment

- Right Door Assembly (1)
- Left Door Assembly (1)

1 From inside the building, put the bottom of the right door assembly (on your left when you are inside the building) behind door jamb into the front frame track.

2 Position the top of the door so that the holes in the door line up with the holes in the door slides.

3 Fasten the door to the door slides using two #10Bx1/2" (13 mm) screws per door slide.

NOTE

The holes in the door slides allow you to adjust the doors. Place the door in the middle holes.

4 Repeat steps 1 through 3 for the left door.

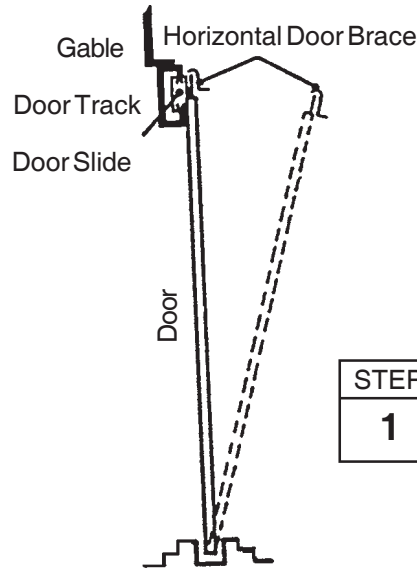

Front Floor Frame Assembly

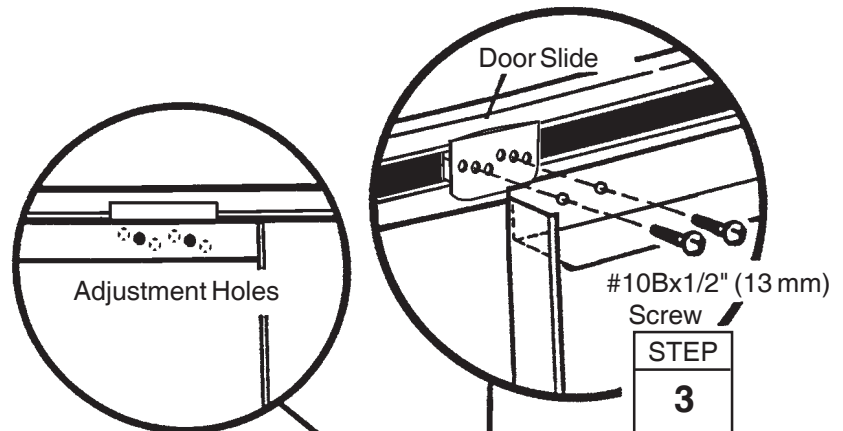

Adjustment Holes Allow Doors to Meet Evenly Along Their Length

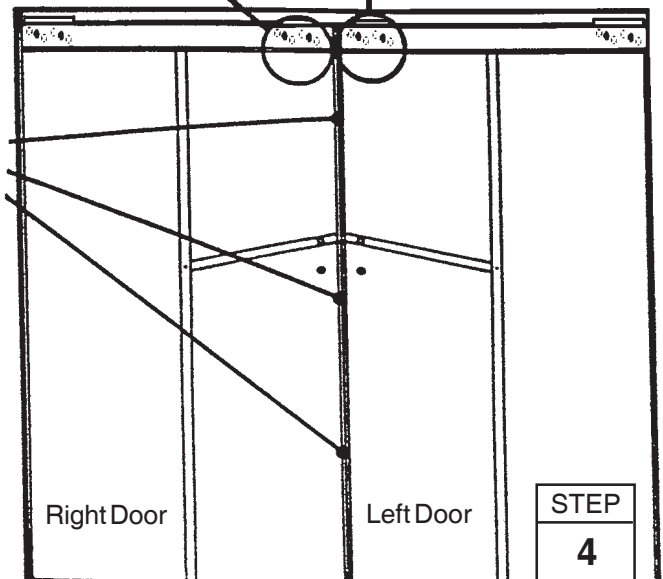

Floor Frame Kit

Bodenrahmen-Bausatz * Kit de cadre pour plancher * Kit de entramado de pisos

FB109-A 697.68385-A Assembly Manual

Montagehandbuch * Manual de ensamblaje

* Guide d'assemblage

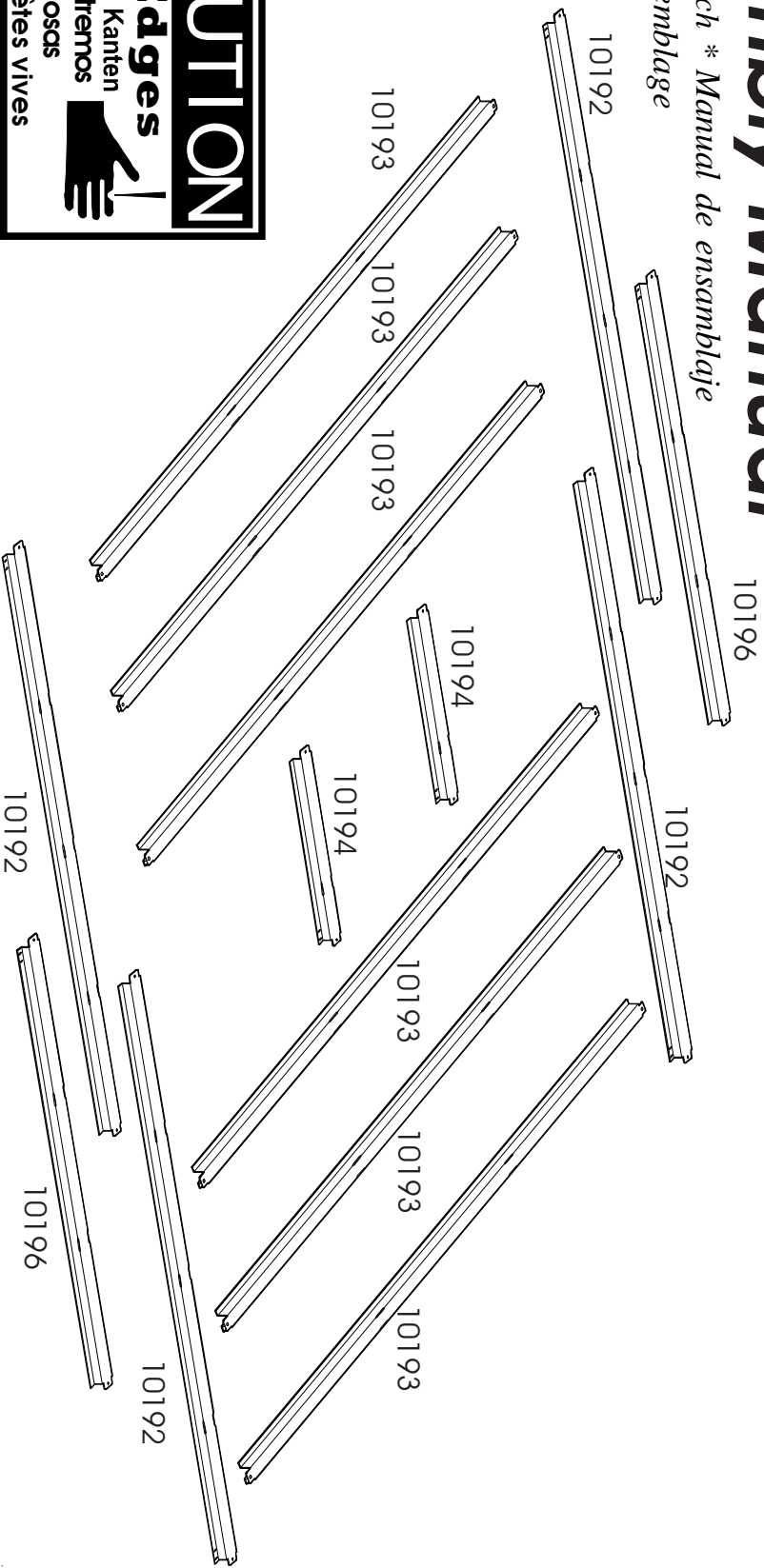

CAUTION

Sharp Edges

Vorsicht Scharfe Kanten
Precaución: extremos
Y esquinas filosas
ATTENTION Arêtes vives



10x7, 10x8, 10x9, 10x10 Buildings

*Bau 3,05 x 2,13	*Bau 3,05 x 2,44	*Bau 3,05 x 2,74	*Bau 3,05 x 3,05
* Edificio de 3,05 x 2,13	* Edificio de 3,05 x 2,44	* Edificio de 3,05 x 2,74	* Edificio de 3,05 x 3,05
* Remise 3,05 x 2,13	* Remise 3,05 x 2,44	* Remise 3,05 x 2,74	* Remise 3,05 x 3,05
Part Name *Teilbezeichnung * Nombre de la pieza * Désignation de la pièce	Qty *Menge *Cantidad *Quantité		
10193	6		
10192	4		
10194	2		

8 x 8 Building

*Bau 2,44 x 2,44	* Edificio de 2,44 x 2,44	* Remise 2,44 x 2,44
Part Name *Teilbezeichnung * Nombre de la pieza * Désignation de la pièce	Qty *Menge *Cantidad *Quantité	
10193	5	
10192	2	
10196	2	



World's Leading Maker
of Storage Buildings®

711680705 — Kit contains extra parts. Bausatz enthält zusätzliche Teile * El juego contiene piezas de sobra * Le nécessaire comprend des pièces supplémentaires

Before You Begin / Site Preparation

1. Before beginning construction, check local building codes regarding footings, location and other requirements. Study and understand this owner's manual.
2. Follow all directions and dimensions carefully.
3. Follow the step sequence carefully for correct results.
4. Be sure all the parts fit together properly before proceeding.
5. **IMPORTANT:** Remove Owner's Manual from main carton

of your storage building.

6. **SAFETY FIRST:** Care must be taken when handling various pieces of your kit since some contain sharp edges. Wear work gloves, eye protection and long sleeves when assembling or performing any maintenance on your kit.
7. **BASIC TOOLS:** No. 2 Phillips screwdriver, pliers, work gloves, tape measure, level and a spade or shovel.
8. **GROUND MUST BE LEVEL:** Be sure Floor Frames lie flat on ground. To

prepare earth bed, remove sod and other debris. Level the high spots with flat shovel and tamp the bed down.

9. DO NOT STEP ON CHANNELS UNTIL FLOORING MATERIAL IS IN PLACE!

10. Separate contents of the carton by the part number while reviewing parts list. Check to be sure that you have all the necessary parts for your kit.

Antes de empezar/Preparación del sitio

1. Antes de empezar la construcción, verifique los códigos de construcción locales relativos a cimentación, localización y otros requisitos. Escudriñe y entienda este manual del propietario.
2. Sigla todas las instrucciones y dimensiones con cuidado.
3. Sigla la secuencia de pasos con cuidado para realizar resultados correctos.
4. Asegure que todas las piezas se junten apropiadamente antes de continuar.
5. **IMPORTANTE:** Saque el Manual del Propietario de la caja de cartón principal de su edificio de almacenaje.
6. **LA SEGURIDAD ANTE TODO:** Hay que tener cuidado al manejar las varias piezas de su juego porque algunas tienen bordes afilados. Póngase guantes de trabajo, protección para los ojos y mangas largas cuando ensamble o cuando dé cualquier mantenimiento a su juego.
7. **HERRAMIENTAS BASICAS:** Destornillador Phillips ním. 2, alicates, guantes de trabajo, cinta métrica, nivel y azada o pala.
8. **EL SUELO DEBE ESTAR NIVELADO:** Asegure que los marcos del piso estén planos en el suelo. Para preparar la base de tierra, quite césped y otros escombros. Nivele los sitios altos con una pala plana y apisona la base.
9. **¡NO PISE LOS CANALES HASTA QUE EL MATERIAL DE PISO ESTE EN SU LUGAR!**
10. Disponga el contenido de la caja de cartón por el número de la pieza mientras repasa la lista de piezas. Controle para asegurar que Vd. tenga todas las piezas necesarias de su juego.

Avant de commencer/Préparation du terrain

1. Avant de commencer la construction, réviser les normes locales de sécurité de construction relatives aux emplacements, à l'emplacement et aux autres exigences.
2. Suivre attentivement toutes les directives et les dimensions.
3. Suivre attentivement la séquence des étapes pour obtenir les résultats désirés.
4. Avant de poursuivre, s'assurer que toutes les pièces sont correctement alignées.
5. **IMPORTANT :** Retirer le Guide du propriétaire qui se trouve dans l'emballage principal de la remise.
6. **SÉCURITÉ D'ABORD :** Manipuler soigneusement les diverses pièces du prêt-à-monter puisque certaines d'entre elles ont des angles coupants. Porter des gants de travail, une protection oculaire et des manches longues pour assembler le prêt-à-monter ou pour effectuer des travaux d'entretien.
7. **OUTILS ESSENTIELS :** tournevis Phillips n° 2, pinces, gants de travail, mètre à ruban, niveau, bêche ou pelle.
8. **EGALISER LE TERRAIN :** S'assurer que les pièces de la charpente du plancher reposent à plat sur le sol. Pour préparer le lit de terre, enlever le gazon et les autres débris. Égaliser les points plus élevés avec une pelle plate et taper le lit de terre.
9. **NE PAS MARCHER SUR LES TRAVERSES AVANT D'AVOIR POSÉ LE REVÊTEMENT DU PLANCHER!**
10. Débattler les pièces selon leur numéro de pièce tout en consultant la liste des pièces. S'assurer que toutes les pièces nécessaires se trouvent dans l'emballage.

Assembly

1. Before assembling this kit, the floor frames packed with the building must be assembled.

- Vor dem Zusammenbau dieses Bausatzes müssen die mit dem Gerätehaus mitgelieferten Bodenrahmen zusammengebaut werden.
- Avant de monter ce kit, les cadres de planchers fournis avec le bâtiment doivent être montés.
- Antes de armar este kit, se deben ensamblar los entramados del piso comprimidos con el edificio.

Bevor Sie anfangen / Vorbereitung der Baustelle

1. Vor Baubeginn überprüfen Sie örtliche Bauvorschriften auf Erfordernisse hinsichtlich Fugflächen, Bauplatz und weitere Erfordernisse. Lesen Sie dieses Besitzerhandbuch sorgfältig und verstehen Sie es.
2. Befolgen Sie alle Anweisungen und Abmessungen sorgfältig. Zur Erzielung richtiger Ergebnisse halten Sie die Reihenfolge der Schritte genau ein.
3. Bevor Sie weitmachen, vergewissern Sie sich, daß alle Teile richtig zusammenpassen.
4. **WICHTIG:** Nehmen Sie das Besitzerhandbuch aus dem Hauptkarton Ihres Lagerschupps heraus.
5. **SICHERHEIT KOMMT ZUERST:** Verschiedene Teile Ihres Bausatzes müssen vorsichtig gehandhabt werden, da sie scharfe Kanten haben. Tragen Sie beim Zusammenbau oder bei der Durchführung von Wartungsarbeiten an Ihrem Bausatz Arbeitshandschuhe, Augenschutz und lange Ärmel.
6. **GRUNDWERKZEUGE:** Nr. 2 Kreuzschlitzschraubenzieher, Zange, Arbeitslandsschuhe, Maßband, Wasserwaage und ein Spaten oder eine Schaufel.
7. **DER BODEN MUSS EBEN SEIN:** Vergewissern Sie sich, daß die Bodenrahmen flach am Boden liegen. Zur Vorbereitung des Erdbetts entfernen Sie die Grasstücke und anderen Schutt. Ebenen Sie höhere Flächen mit einer flachen Schaufel ein und stampfen Sie das Bett nieder.
8. **STEGEN SIE ERST AUF DIE KANÄLE, WENN DAS BODENMATERIAL IST!**
9. Sortieren Sie den Kartoninhalt nach der Teilnummer, während Sie die Teilliste überprüfen. Vergewissern Sie sich, daß Sie alle für Ihren Bausatz notwendigen Teile haben.

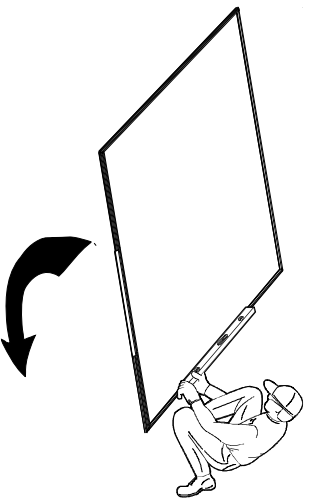

Montage

1. Before assembling this kit, the floor frames packed with the building must be assembled.

- Vor dem Zusammenbau dieses Bausatzes müssen die mit dem Gerätehaus mitgelieferten Bodenrahmen zusammengebaut werden.
- Avant de monter ce kit, les cadres de planchers fournis avec le bâtiment doivent être montés.
- Antes de armar este kit, se deben ensamblar los entramados del piso comprimidos con el edificio.

If you find a part missing call 1-800-851-1085

• Si encuentra que le hacen falta piezas, llame al 1-800-851-1085

or write * Oder schreiben Sie an * o escriba * ou écrire

Arrow Group Industries

1101 North 4th Street, Breese, Illinois 62230

Include Model Number, Part Number and Part Name

Bitte geben Sie Ihre Modellnummer, Teilnummer und

Teilbezeichnung an.

• Proporcione número del modelo, número de la pieza y número de la pieza.

• Indiquer le numéro de modèle, le numéro de pièce et la désignation de la pièce.

10 x 7, 10 x 8, 10 x 9 & 10 x 10

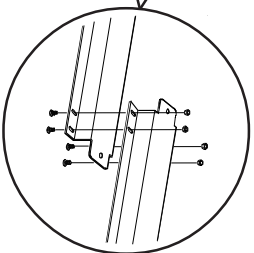
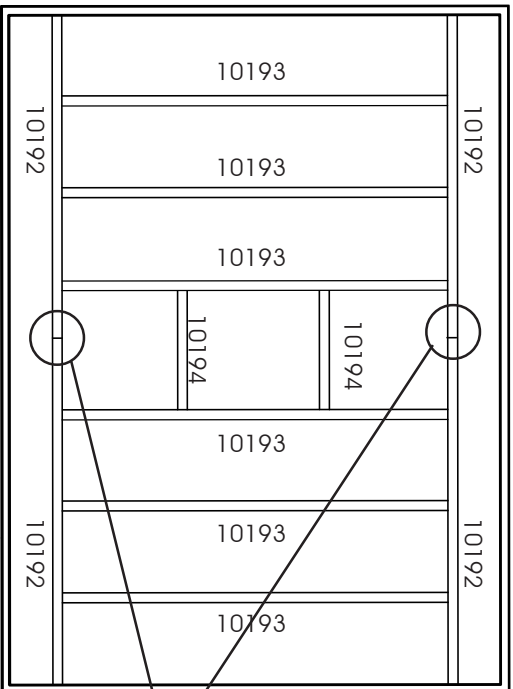

2. Assemble parts that overlap.

- *Montieren Sie über lappende Teile.*
- *Ensamble las piezas que solapan.*
- *Assembler les pièces en recouvrement.*

3. Bend Tabs and assemble remaining parts.

- *Biegen Sie die Endstücke um und bauen Sie die verbleibenden Teile zusammen.*
- *Doble las lengüetas y ensamble las piezas que quedan.*
- *Plier les languettes et assembler les autres pièces.*

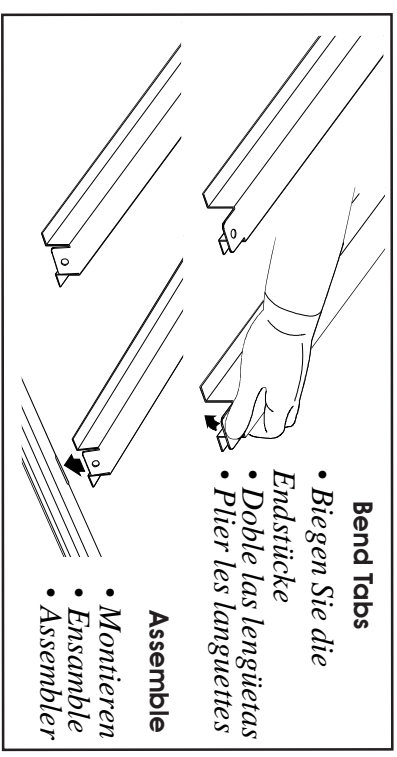

- **Bend Tabs**
- *Biegen Sie die Endstücke*
- *Doble las lengüetas*
- *Plier les languettes*
- **Assemble**
- *Montieren*
- *Ensamble*
- *Assembler*

IMPORTANT:

Make sure overlaps are positioned on same side of building frame.

WICHTIG: Stellen Sie sicher, daß sich die Überlappungen auf derselben Seite des Gebäuderahmens befinden.

IMPORTANTE: Asegure que los solapos se coloquen en el mismo lado del marco del edificio.

IMPORTANT: Les trous doivent être orientés vers le centre.

The perimeter is the floor frame from the building.

Der Bodenrahmen des Gerätehauses ist die Eingrenzung.

Le périmètre est le cadre

de plancher du bâtiment.

El perímetro es el marco del piso desde el edificio.

Plywood Requirements

- *Erfordernisse für das Sperrholz • Madera multilaminar requerida*
- *Exigences en matière de contre-plaqué*

Three (3) Sheets 4' x 8' for 10 x 9, 10 x 8 & 10 x 7

Two (2) Sheets for 8 x 8

Four (4) Sheets for 10 x 10

- *Drei (3) Platten zu (1,22 mx2,44 m) für 2,44mx2,44m und 3,05mx2,13m.*
- *Zwei (2) Platten zu (1,22 mx2,44 m) für 3,05mx3,05m.*
- *Vier (4) Platten zu (1,22 mx2,44 m) para 10 x 9 y 10 x 8 y 10 x 7*
- *Tres (3) hojas de 4' x 8' (1,22 m x 2,44 m) para 10 x 9 y 10 x 8 y 10 x 7*
- *Dos (2) hojas de 4' x 8' (1,22 m x 2,44 m) para 8 x 8*
- *Cuatro (4) hojas de 4' x 8' (1,22 m x 2,44 m) para 10 x 10*
- *Trois (3) panneaux de 4' x 8' pour 10 x 9 et 10 x 8 et 10 x 7*
- *Deux (2) panneaux de 4' x 8' pour 8 x 8*
- *Quatre (4) panneaux de 4' x 8' pour 10 x 10*

5/8" Minimum Thickness. Exterior Grade

- *1,6 cm Mindeststärke. Qualitätsgrad für Außenanwendungen*
- *Un mínimo de 5/8" (1,6 cm) de grueso. Calidad apropiada para el exterior*
- *Épaisseur minimale : 5/8". Qualité extérieure*

4. Frame must be square and level.

- *Der Rahmen muß rechteckig und eben sein*
- *El marco del piso debe ser cuadrado y nivelado*
- *La charpente du plancher doit être d'équerre et de niveau.*

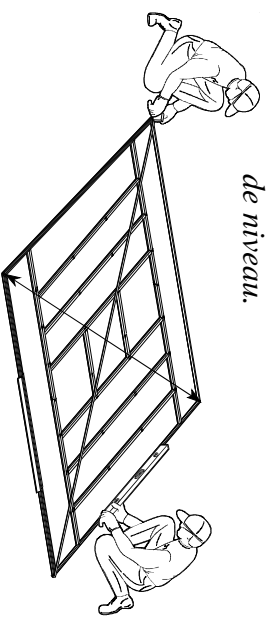

Installing Plywood

- *Einbau des Sperrholzes • Instalación de la madera multilaminar*
- *Installation du contre-plaqué*

1. Cut Plywood to dimensions shown.

- *Schneiden Sie das Sperrholz auf die gezeigten Maße zu.*
- *Corte la madera multilaminar según las dimensiones que se muestran.*
- *Couper les panneaux de contre-plaqué selon les dimensions indiquées.*

2. Fasten to frame with dry wall screws.

- *Befestigen Sie es mit Schnellbauschrauben am Rahmen.*
- *Asegúrela al marco con tornillos para carrón-yeso.*
- *Fixer les pièces à la charpente avec des vis à placoplâtre.*

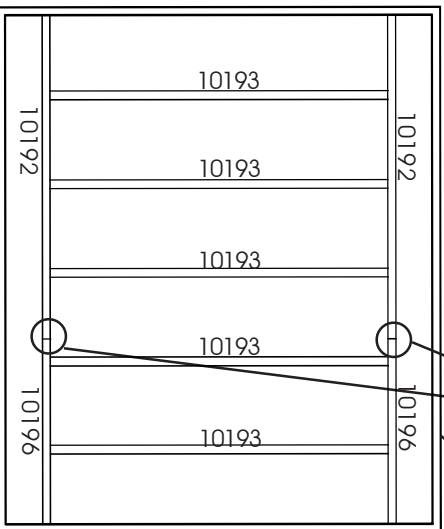

8 x 8

10 X 9

<p>Sheet #2 16" x 48" Plate 2 * Hoja núm. 2 * Panneau nº 2 40.6 cm x 121.9 cm</p>	<p>Sheet #2 16" x 22 1/8" Plate 2 * Hoja núm. 2 * Panneau nº 2 40.6 cm x 56.2 cm</p>	<p>Sheet #2 16" x 48" Plate 2 * Hoja núm. 2 * Panneau nº 2 40.6 cm x 121.9 cm</p>
<p>Sheet #1 48" x 84" Plate 1 * Hoja núm. 1 * Panneau nº 1 121.9 cm x 213.4 cm</p> <p>MODEL ES109 ONLY Modell ES109 nur Modèle ES109 seulement Modelo ES109 sólo</p> <p>Sheet #1 48" x 83 1/16" Plate 1 * Hoja núm. 1 * Panneau nº 1 121.9 cm x 211 cm</p>	<p>Sheet #2 46 7/8" x 22 1/8" Plate 2 * Hoja núm. 2 * Panneau nº 2 119 cm x 56.2 cm</p>	<p>Sheet #3 48" x 84" Plate 3 * Hoja núm. 3 * Panneau nº 3 121.9 cm x 213.4 cm</p> <p>MODEL ES109 ONLY Modell ES109 nur Modèle ES109 seulement Modelo ES109 sólo</p> <p>Sheet #3 48" x 83 1/16" Plate 3 * Hoja núm. 3 * Panneau nº 3 121.9 cm x 211 cm</p>
<p>Modell ES109 nur *Modèle ES109 seulement *Modelo ES109 sólo</p>		

Installing Plywood

10 X 8

<p>Sheet #1 48" x 87 3/4" Plate 1 * Hoja núm. 1 * Panneau nº 1 121.9 cm x 222.9 cm</p>	<p>Sheet #2 48" x 87 3/4" Plate 2 * Hoja núm. 2 * Panneau nº 2 121.9 cm x 222.9 cm</p>
<p>Sheet #3 22 1/8" x 87 3/4" Plate 3 * Hoja núm. 3 * Panneau nº 3 56.2 cm x 222.9 cm</p>	<p>Sheet #3 22 1/8" x 87 3/4" Plate 3 * Hoja núm. 3 * Panneau nº 3 56.2 cm x 222.9 cm</p>

10 X 7

<p>Sheet #1 48" x 76" Plate 1 * Hoja núm. 1 * Panneau nº 1 121.9 cm x 193.0 cm</p>	<p>Sheet #2 48" x 76" Plate 2 * Hoja núm. 2 * Panneau nº 2 121.9 cm x 193.0 cm</p>
<p>Sheet #3 22 1/8" x 76" Plate 3 * Hoja núm. 3 * Panneau nº 3 56.2 cm x 190.3 cm</p>	<p>Sheet #3 22 1/8" x 76" Plate 3 * Hoja núm. 3 * Panneau nº 3 56.2 cm x 190.3 cm</p>

8 X 8

<p>Sheet #3 20 3/4" x 48" Plate 3 * Hoja núm. 3 * Panneau nº 3 52.7 cm x 121.9 cm</p>	<p>Sheet #4 20 3/4" x 22 1/8" Plate 4 * Hoja núm. 4 * Panneau nº 4 52.7 cm x 56.2 cm</p>	<p>Sheet #3 20 3/4" x 48" Plate 3 * Hoja núm. 3 * Panneau nº 3 52.7 cm x 121.9 cm</p>
<p>Sheet #1 48" x 88 3/4" Plate 1 * Hoja núm. 1 * Panneau nº 1 121.9 cm x 225.4 cm</p>	<p>Sheet #3 46 7/8" x 22 1/8" Plate 3 * Hoja núm. 3 * Panneau nº 3 119 cm x 56.2 cm</p>	<p>Sheet #2 48" x 88 3/4" Plate 2 * Hoja núm. 2 * Panneau nº 2 121.9 cm x 225.4 cm</p>
<p>Modell ES109 nur *Modèle ES109 seulement *Modelo ES109 sólo</p>		

<p>Sheet #1 48" x 87 3/4" Plate 1 * Hoja núm. 1 * Panneau nº 1 121.9 cm x 222.9 cm</p>	<p>Sheet #2 46 5/8" x 87 3/4" Plate 2 * Hoja núm. 2 * Panneau nº 2 118.4 cm x 222.9 cm</p>
--	--

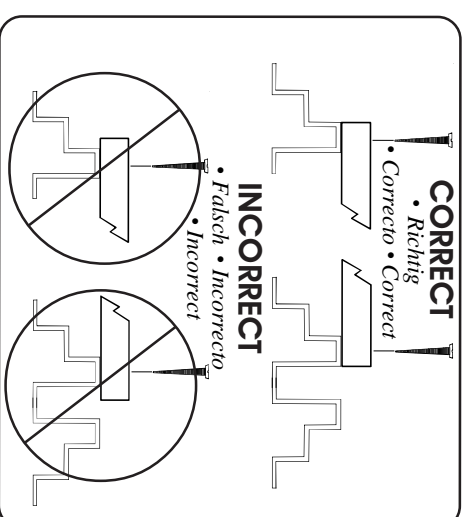

Finish construction of your storage Building

following the Assembly Instructions.

- Beenden Sie den Bau Ihres Lagerstüppens und befolgen Sie die Montageanleitungen.
- Complete la construcción de su edificio de almacenaje siguiendo las instrucciones para el ensamblaje.
- Finir la construcción de la remise en suivant les directives d'assemblage.

HM10867

NP10867

RM108-A

RMG108

RMW108

VH108-A

WL10867

V32

SOME FACTS ABOUT RUST

Rusting is a natural oxidizing process that occurs when bare metal is exposed to moisture. Problem areas include screw holes, unfinished edges, or where scrapes and nicks occur in the protective coating through normal assembly, handling and use. Identifying these natural rusting problem areas and taking some simple rust protection precautions can help to stop rust from developing, or stop it quickly as soon as it appears.

1. Avoid nicking or scraping the coating surface, inside and out.
2. Use all the washers supplied. In addition to protecting against weather infiltration, the washers protect the metal from being scraped by the screws.
3. Keep roof, base perimeter and door tracks free of debris and leaves which may accumulate and retain moisture. These can do double damage since they give off acid as they decay.
4. Touch up scrapes or nicks and any area of visible rust as soon as possible. Make sure the surface is free of moisture, oils, dirt or grime and then apply an even film of high quality touch-up paint.