

Owner's Manual & Assembly Instructions

XZ01

Model No. GSA83

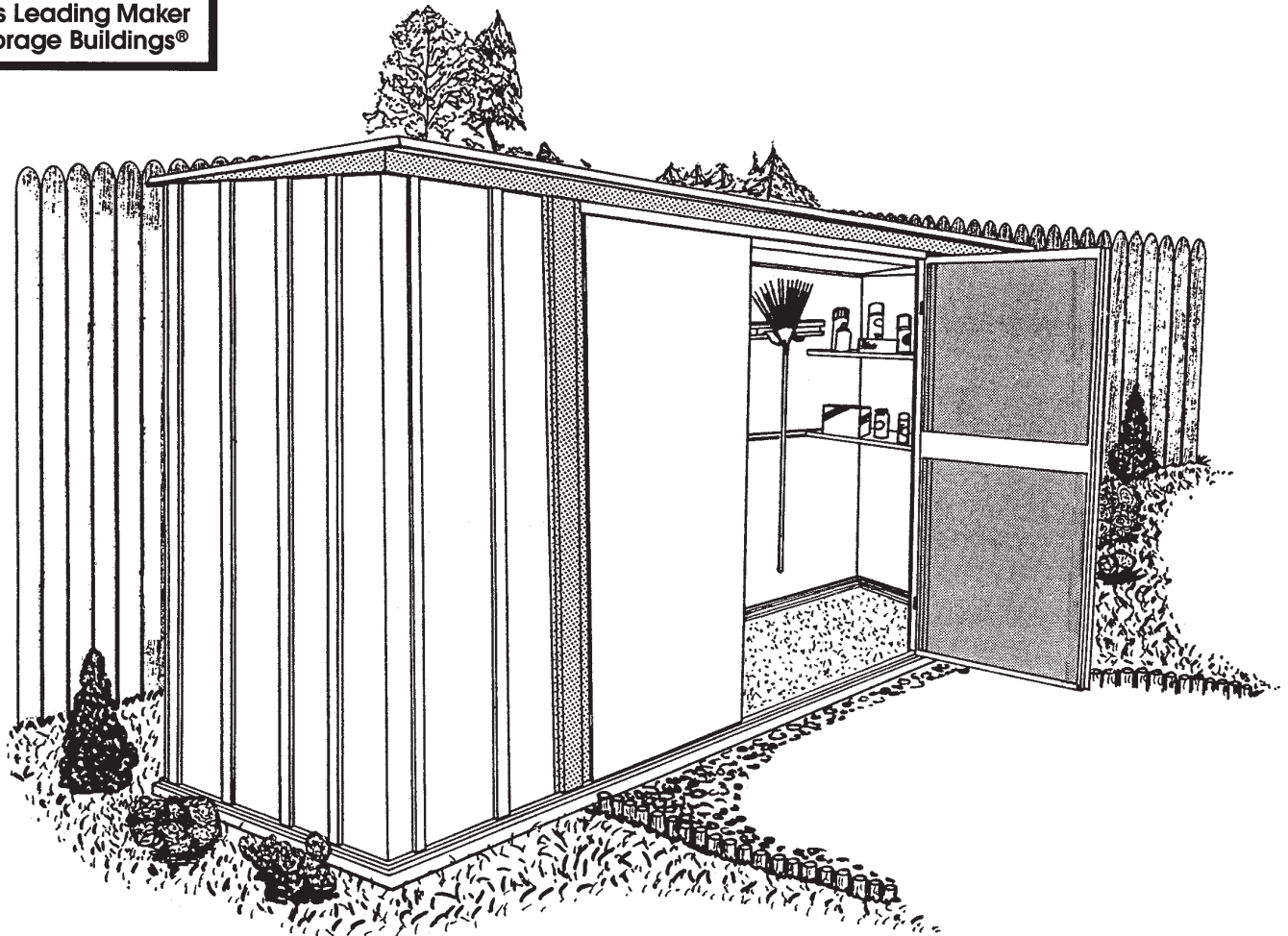

716230210

Storage Area: 23 Sq. Ft. 122 Cu. Ft.
2,1 m² 3,5 m³



CAUTION: SOME PARTS HAVE SHARP EDGES. CARE MUST BE TAKEN WHEN HANDLING THE VARIOUS PIECES TO AVOID A MISHAP. FOR SAFETY SAKE, PLEASE READ SAFETY INFORMATION PROVIDED IN THIS MANUAL BEFORE BEGINNING CONSTRUCTION. WEAR GLOVES WHEN HANDLING METAL PARTS.

BUILDING DIMENSIONS * Size rounded off to the nearest foot

*Approx. Size	Base Size	Exterior Dimensions (Roof Edge to Roof Edge)			Interior Dimensions (Wall to Wall)			Door Opening	
		Width	Depth	Height	Width	Depth	Height	Width	Height
8' x 3'	96 7/8" x 38"	99 3/8"	39 1/4"	65 5/8"	94 1/8"	35 3/16"	64 7/16"	50 1/4"	59 3/4"
2,4 m x 0,9 m	246,1 cm x 96,4 cm	252,4 cm	99,7 cm	166,7 cm	239,1 cm	89,4 cm	163,7 cm	127,6 cm	151,8 cm

BEFORE YOU BEGIN....

XA02

Owner's Manual

Before beginning construction, check local building codes regarding footings, location and other requirements. Study and understand this owner's manual.

Important information and helpful tips will make your construction easier and more enjoyable.

Assembly Instructions: Instructions are supplied in this manual and contain all appropriate information for your building model. Review all instructions before you begin, and during assembly, follow the step sequence carefully for successful results.

Flooring and Anchoring: Your storage building must be anchored to prevent wind damage. A base is necessary to construct a square and level building. Anchoring and base materials are not included with your building. Your assembly instructions provide information on a few methods commonly used to secure and level a storage building.

Parts and Parts List: Check to be sure that you have all the necessary parts for your building.

- All part numbers can be found on the parts. All of these numbers (before the -) must agree with the numbers on the Parts List page.

- If you find that a part is missing, include the model number of your building and contact the retailer where you purchased your shed.**

- Separate contents of the carton by the part number while reviewing parts list. The first few steps show how to join related parts to make larger sub assemblies which will be used later.

- Familiarize yourself with the hardware and fasteners for easier use during construction. These are packaged within the carton. Note that extra fasteners have been supplied for your convenience.

PLAN AHEAD....

XA03

Watch the Weather: Be sure the day you select to install your building is dry and calm. Do not attempt to assemble your building on a windy day. Be careful on wet or muddy ground.

Teamwork: Whenever possible, two or more people should work together to assemble your building. One person can position parts or panels while the other is able to handle the fasteners and the tools.

Tools and Materials: These are some basic tools and materials you will need for the construction of your building. Decide which method of anchoring and the type of base you wish to use in order to form a complete list of the materials you will need.

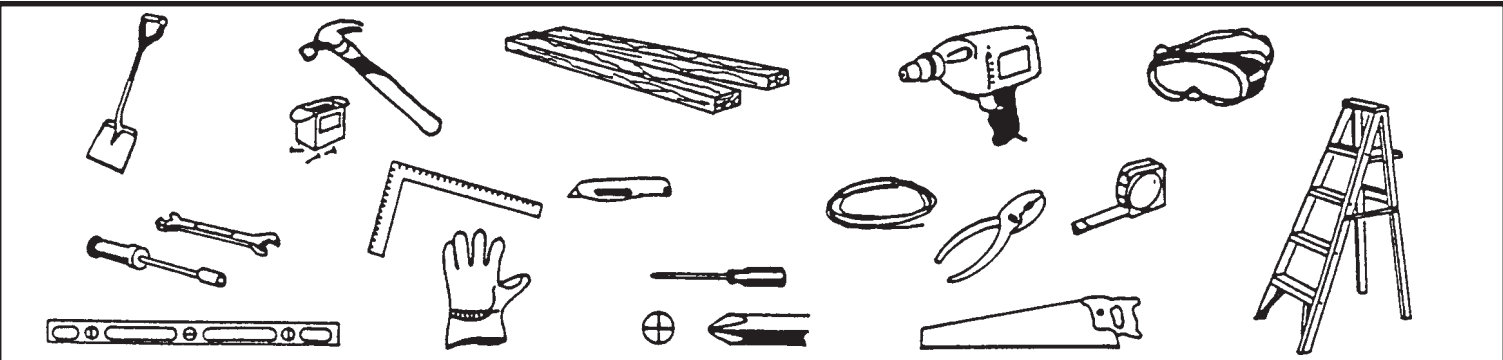

<p>Required</p> <ul style="list-style-type: none">• Eye Goggles• No. 2 Phillips Screwdriver (With Hardened Magnetic Tip) <p>Note: A power screwdriver or variable speed drill with Phillips-tip attachment can speed assembly by as much as 40%.</p>	<p>Required</p> <ul style="list-style-type: none">• Work Gloves• Step Ladder• Utility Knife / Scissors• Pliers• Carpenter's Level• Tape Measure	<p>Optional Time-Savers</p> <ul style="list-style-type: none">• Wrench / Nut Driver• Electric / Cordless Drill• Square• String (for squaring frame)	<p>Base Preparation</p> <ul style="list-style-type: none">• Hammer and Nails• Spade or Shovel• Hand Saw / Power Saw• Lumber and/or Concrete
---	--	--	--

Selecting and Preparing Your Site: Before assembly, you will want to decide on a location for your building. The best location is a level area with good drainage.

- Allow enough working space for ease of moving parts into position during assembly. Be sure there will be enough space at entrance for doors to open fully and enough space around the building to be able to fasten the panel screws from the outside.

- Before you begin the first steps in assembling your parts, a base should be constructed and an anchoring system should be ready to use.

SAFETY FIRST...

XA04

Safety precautions are important to follow throughout the construction of your building.

•Care must be taken when handling various pieces of your building since some contain sharp edges. Please wear work gloves, eye protection and long sleeves when assembling or performing any maintenance on your building.

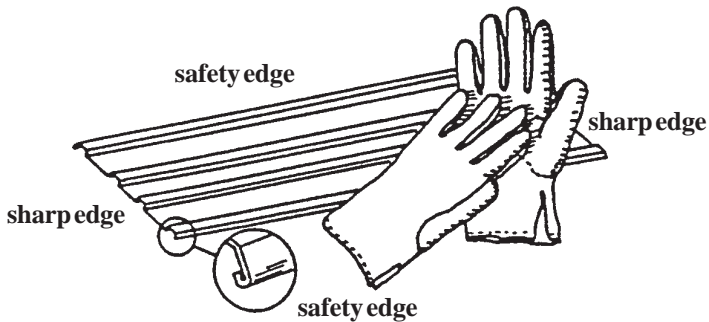

•Practice caution with the tools being used in the assembly of this building. Be familiar with the operation of all power tools.

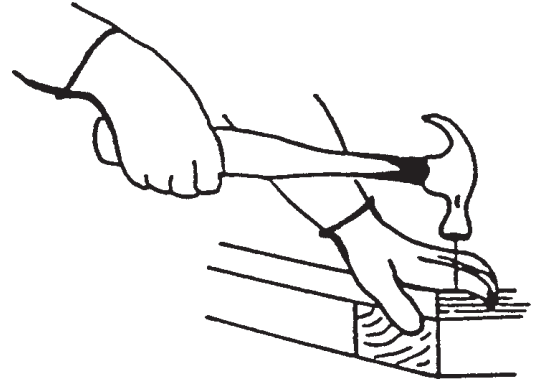

•Keep children and pets away from worksite to avoid distractions and any accidents which may occur.



•Do not attempt to assemble the building if parts are missing because any building left partially assembled may be seriously damaged by light winds.

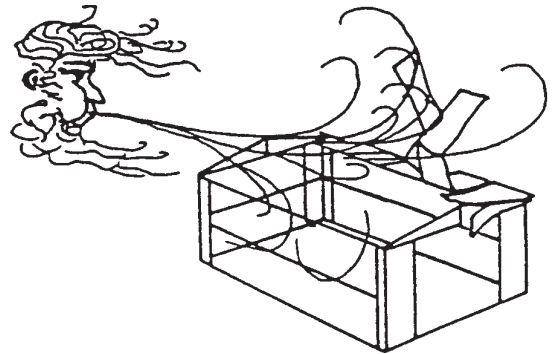

•Never concentrate your total weight on the roof of the building. When using a step ladder make sure that it is fully open and on even ground before climbing on it.

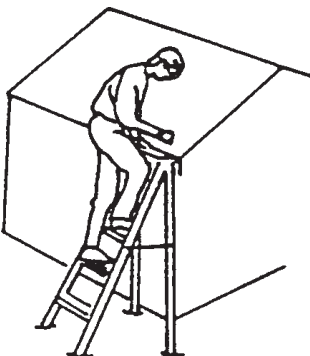

•Do not attempt to assemble the building on a windy day, because the large panels acting as a "sail", can be whipped about by the wind making construction difficult and unsafe.

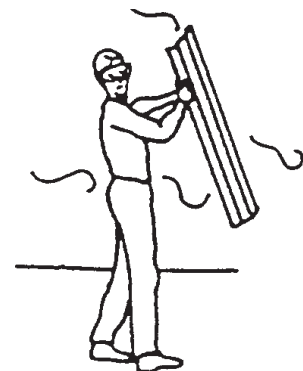

CARE & MAINTENANCE....

XA05

Finish: For long lasting finish, periodically clean and wax the exterior surface. Touch-up scratches as soon as you notice them on your unit. Immediately clean the area with a wire brush; wash it and apply touch-up paint per manufacturer's recommendation.

Roof: Keep roof clear of leaves and snow with long handled, soft-bristled broom. Heavy amounts of snow on roof can damage building making it unsafe to enter.

Doors: Always keep the door tracks clear of dirt and other debris that prevent them from sliding easily. Lubricate door track annually with furniture polish or silicone spray. Keep doors closed and locked to prevent wind damage.

Fasteners: Use all washers supplied to protect against weather infiltration and to protect the metal from being scratched by screws. Regularly check your building for loose screws, bolts, nuts, etc. and retighten them as necessary.

Moisture: A plastic sheet (vapor barrier) placed under the entire floor area with good ventilation will reduce condensation.

Other Tips....

- Wash off inked part numbers on coated panels with soap and water.
- Silicone caulking may be used for watertight seals throughout the building.

Do not store swimming pool chemicals in your building. Combustibles and corrosives must be stored in air tight approved containers.

Keep this Owner's Manual and Assembly Instructions for future reference.

Hardware

XZ06



65103
#8-32 Hex Nut (108)



65941
#6-32 Hex Nut (24)
(Packed with Screws)



65923
#8-32x3/8" (10 mm)
Bolt (108)



65004
#8Ax5/16" (8 mm)
Screw (242)



66714
#6-32x7/16" (11 mm)
Flat Hd Bolt (24)
(Packed with Screws)



65958
#8-32x7/8" (22 mm)
Bolt (2)
(Packed with Screws)

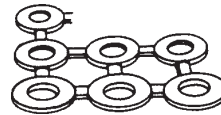

66646
Washer (257)
(7 sheets of 40)



66148
Cap Protector (14)

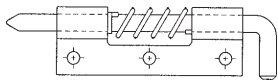

66684
Spring Latch (2)



67468
Peak Cap (1)

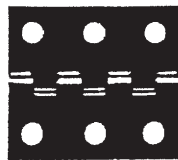

66609
Hinge (4)

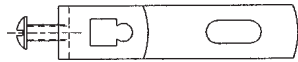

66054
Latch - Attic Door (1)



66183
Roof Trim Cap
(2 right & 2 left)

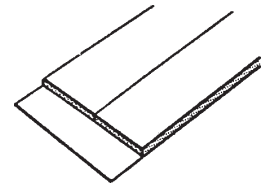

67236
Adhesive Pad (2)

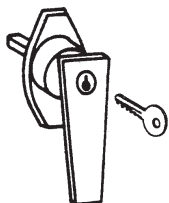

66043
Locking Handle (1)

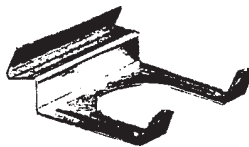

66149
Tool Hook (5)



66150
Screw Driver Holder (1)

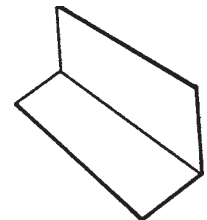

66082
Corner Cap (2)

Anchoring

XA07

Anchoring Down The Building

It is important that the entire floor frame be anchored after the building is erected.

Below are recommended ways of anchoring.

Anchoring into Wood/Post:

Use 1/4" (6 mm) Wood Screws. There are 1/4" (6 mm) dia. holes provided in the frames for proper anchoring.

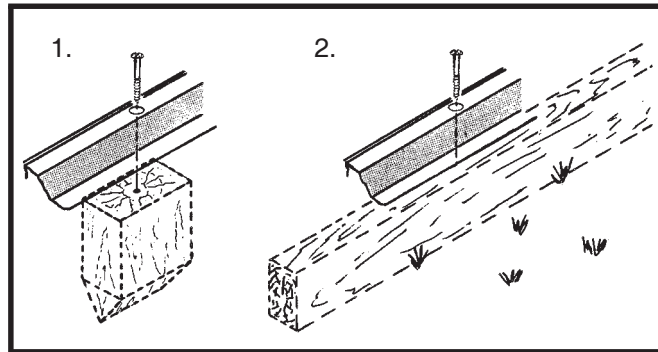

Anchoring into Concrete:

1. For poured concrete slab or footing or patio blocks:
Use 1/4" x 2" (6 mm x 51 mm) Lag Screws.

2. For Anchor Post of Concrete poured after building is erected:
Use 1/4" x 6" (6 mm x 152 mm) Lag Screws.

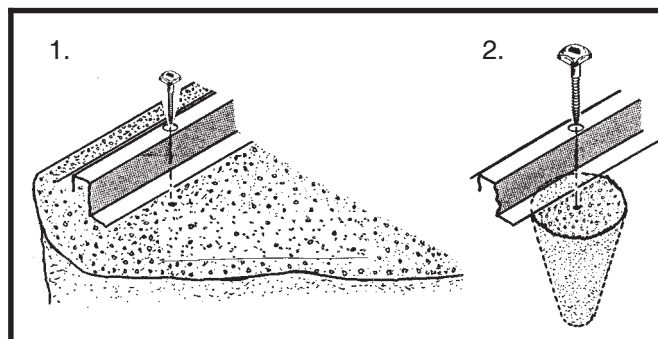

Parts List

XZ08

Assembly Key No.	Part Number	Part Description	Quantity in Carton	Check List
1	10202	Side Floor Frame	2	
2	9866	Outer Front Floor Frame	2	
3	10201	Center Front Floor Frame	1	
4	9868	Rear Floor Frame	2	
5	10199	Floor Brace	2	
6	9870	Right Front Corner Panel	1	
7	9871	Left Front Corner Panel	1	
8	9872	Right Rear Corner Panel	1	
9	9873	Left Rear Corner Panel	1	
10	9874	Wall Panel	2	
11	9875	Front Wall Panel	2	
12	9876	Wall Panel	2	
13	9877	Wall Panel	1	
14	9878	Right Roof Panel	1	
15	9879	Left Roof Panel	1	
16	9880	Roof Panel	2	
17	9881	Roof Panel	1	
18	9927	Rear Wall Channel	2	
19	9883	Rear Wall Angle	2	
20	9884	Shelf	4	
21	9885	Roof Beam	2	
22	10184	Main Door Header	1	
23	9947	Outer Door Header	1	
24	9945	Main Header	1	
25	9889	Outer Header	1	
26	9890	Right Gable	1	
27	9891	Left Gable	1	
28	9892	Right Door Jamb	1	
29	9893	Left Door Jamb	1	
30	9940	Right Door	1	
31	9941	Left Door	1	
32	10183	Door Latch Brace	1	
33	9897	Tool Bar	1	
34	9898	Right Roof Trim	2	
35	9899	Left Roof Trim	2	
36	10200	Floor Channel	4	
37	9905	Door Brace	4	
38	10176	Astragal	1	
39	67734	Foam Board	2	
40	9944	Vertical Door Brace	2	

Assembly by Key No.

XZ09

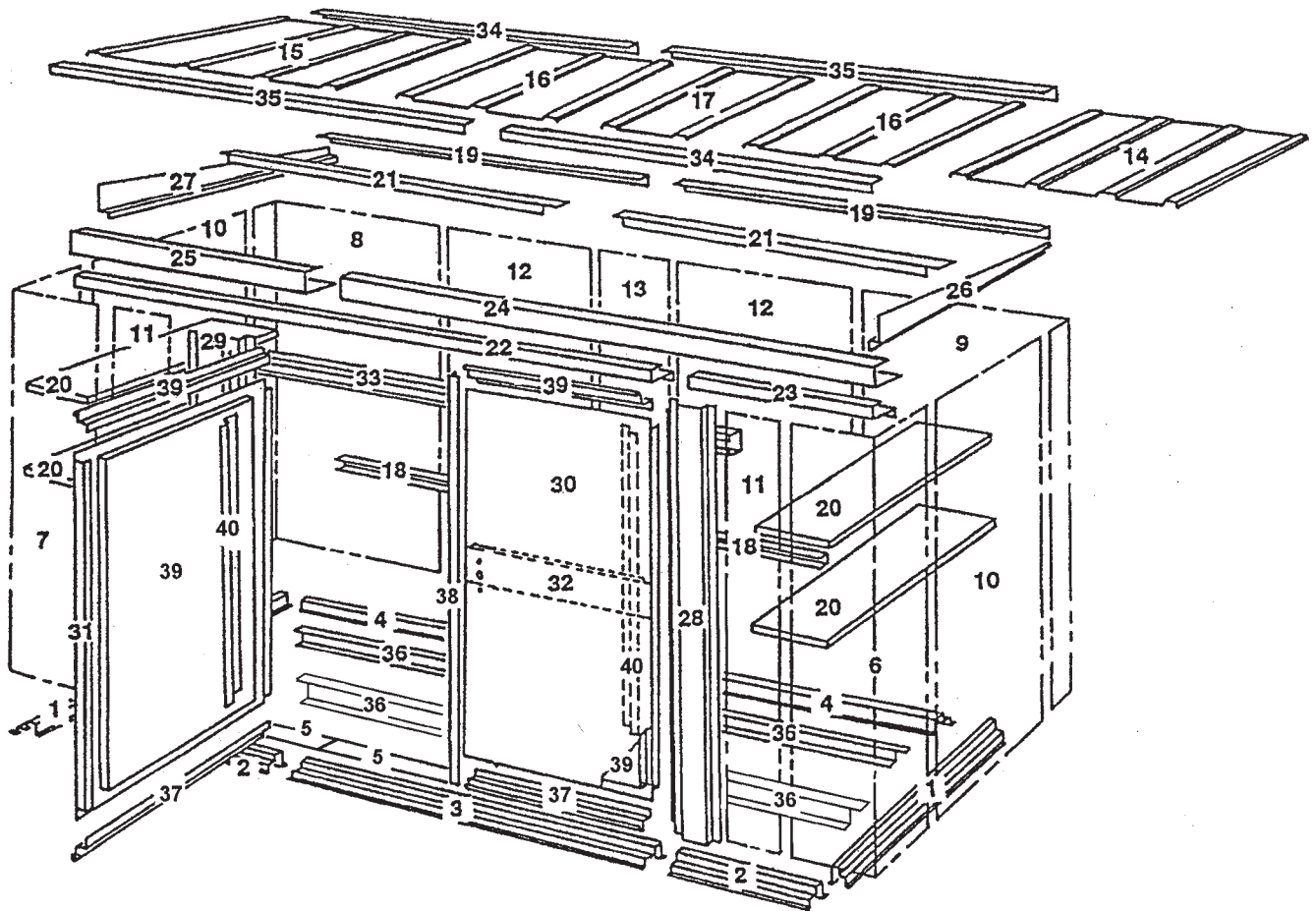

Step 1

XZ10

● Parts Needed For ● Floor Frame Assemblies

- 9866 Outer Front Floor Frame (2)
- 10201 Center Front Floor Frame (1)
- 9868 Rear Floor Frame (2)

The front floor frame is made up of three pieces. The rear floor frame is made up of two pieces. The holes in these pieces will align when the pieces are positioned with correct amount of overlap. The illustrations below show the proper overall length for the rear and front. Proceed as follows:

1 Place the **outer front floor frames** as shown. Position the **center front floor frame** on top of the two outer front floor frames. Join the frames by inserting six bolts and nuts.

2 Overlap the **rear floor frames** as shown. The holes in these pieces will align when the pieces are positioned with correct amount of overlap. See the illustrations below for the proper overall length of the rear floor frame. Join the frames by inserting three bolts and nuts as shown.

3 Double check the length of each.

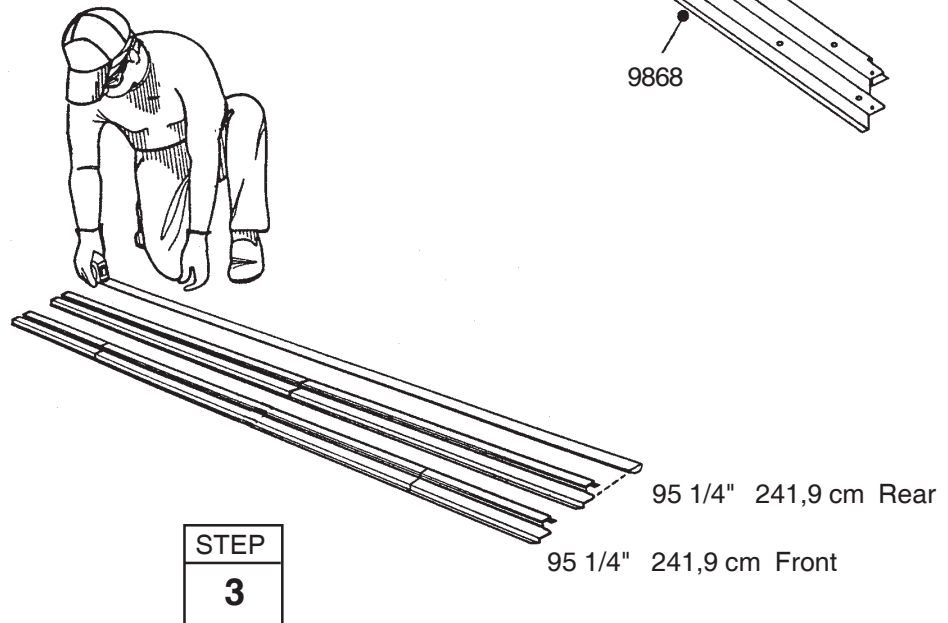
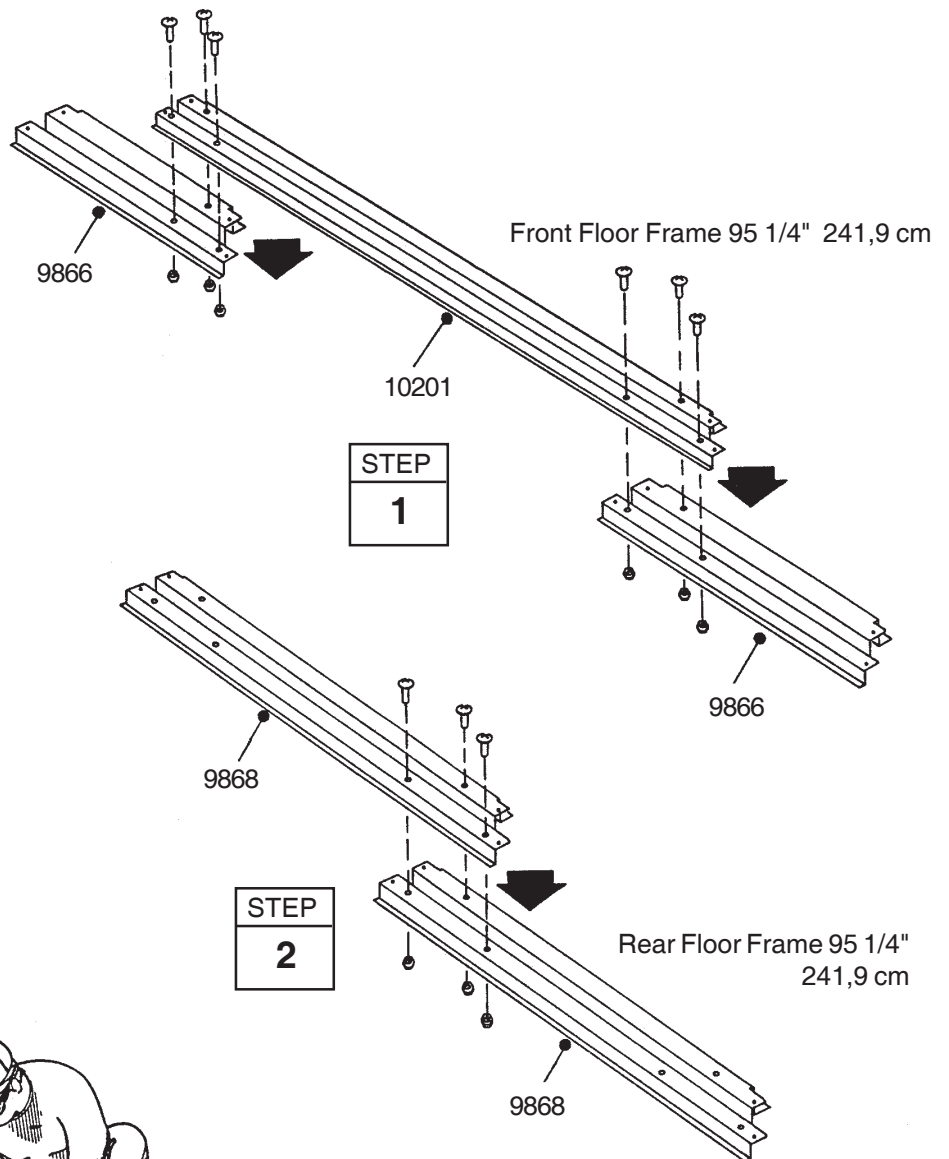

Step 2

XZ11

● Parts Needed For ● Floor Frame

- Front Floor Assembly (1)
- 10202 Side Floor Frame (2)
- Rear Floor Assembly (1)

1 Place the floor frame pieces that you assembled on the ground. Assemble the four corners of the floor frame using two screws at each corner as shown.

2 Measure the floor frame diagonally. When the diagonal measurements are equal, the floor frame is square.

The floor frame *must be square and level* or holes will not align.

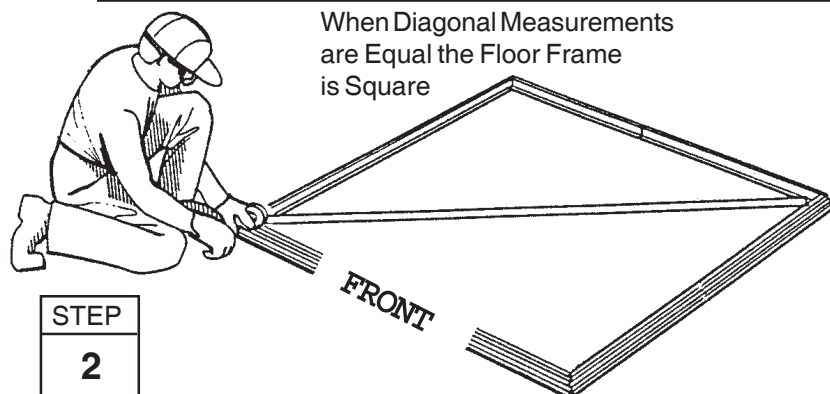
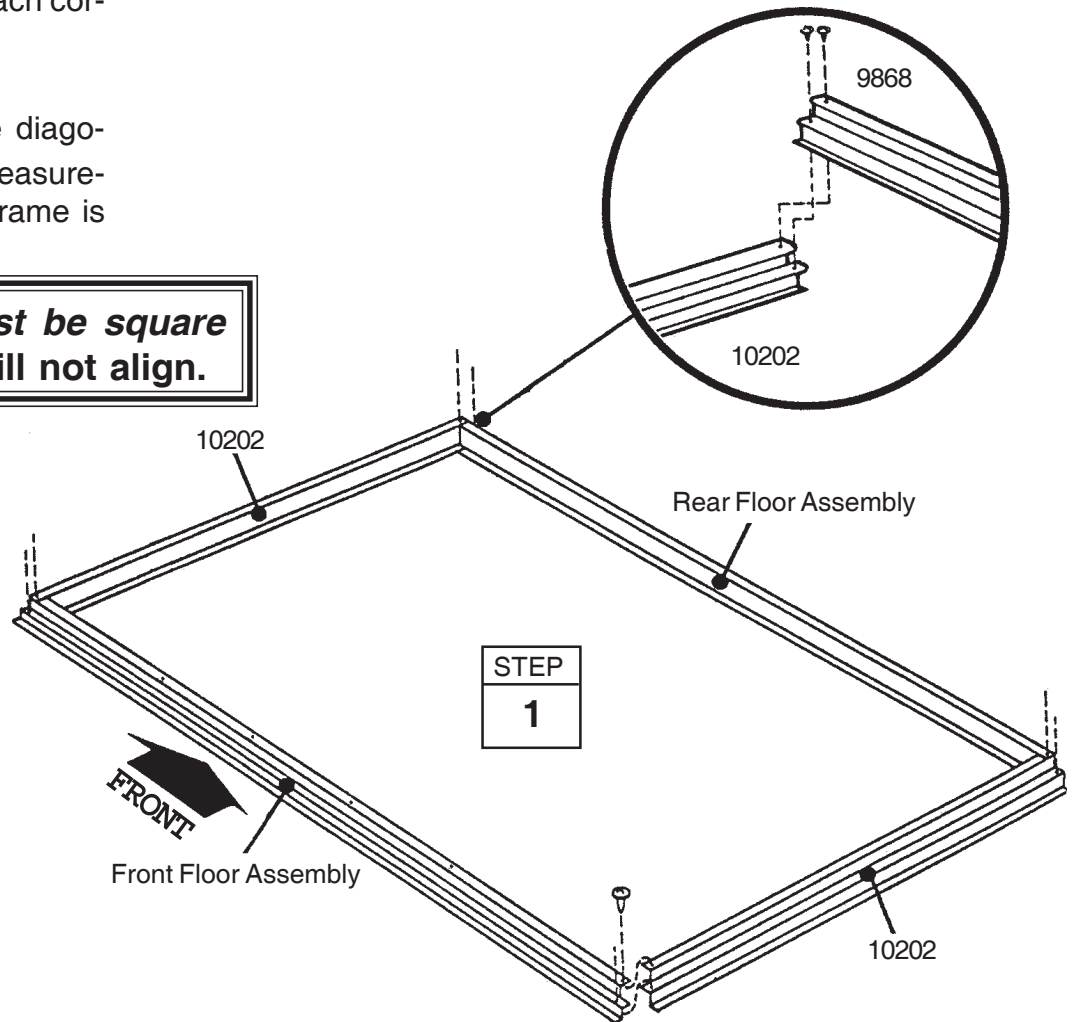

Step 3

XZ12

● Parts Needed For ● Floor Frame Kit

● 10200 Channel (4)

1 Snap **channels 10200** together as shown. Join the channels by inserting four nuts and bolts. Make two complete assemblies.

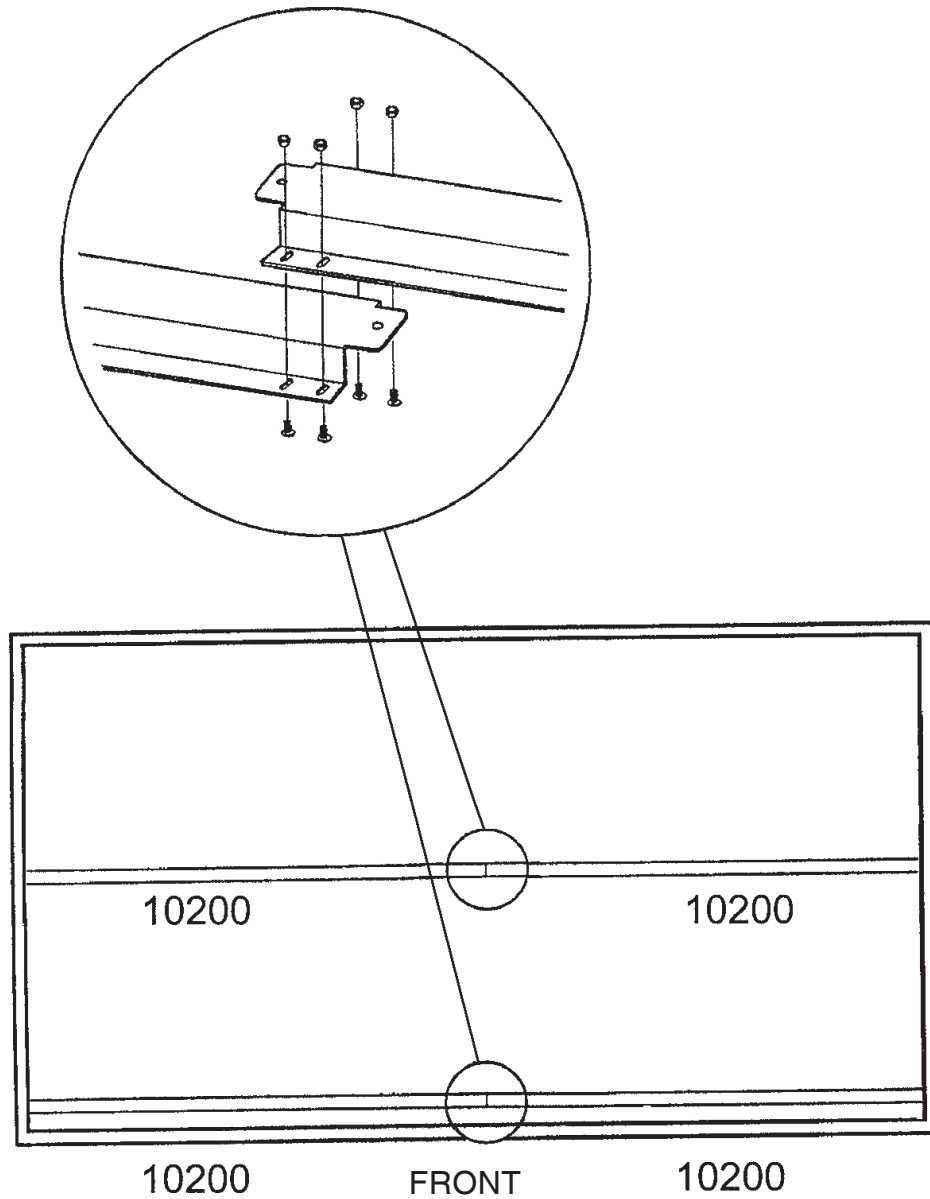

Step 4

XZ13

● Parts Needed For ● Attaching Floor Frame Kit

- Floor Frame Assembly (1)
- Floor Frame Kit (1)
- 10199 Floor Brace (2)

1 Do not attach decking material at this time!

NOTE: FLOOR FRAME MUST BE LEVEL AND SQUARE BEFORE PROCEEDING!

2 Check floor frame for slots.

3 Bend tabs and assemble parts.

4 Overlap slots on **10199** and attach to front floor frame using eight screws.

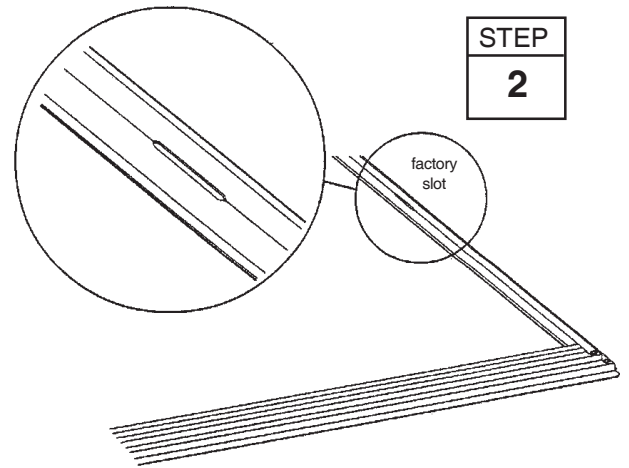

STEP
3

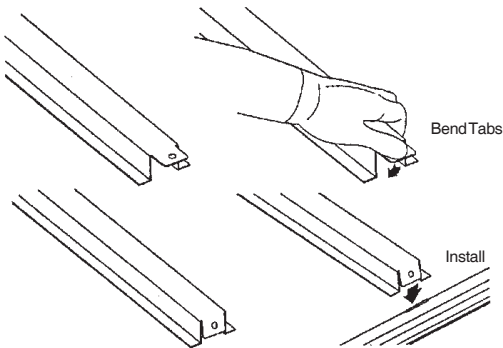

STEP
4

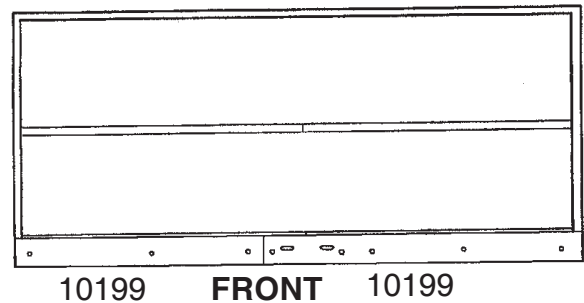

**FRAME MUST BE SQUARE
AND LEVEL**

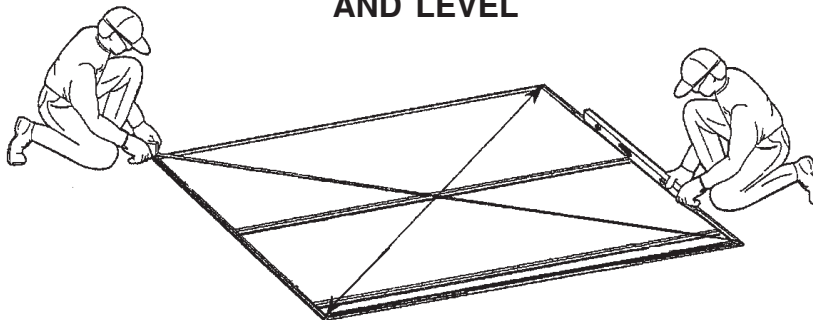

Step 5

Finishing Material

XZ14

Select one of the suggested finishing materials. Be sure Floor Frame Kit lies flat on the ground. To prepare the earth bed, remove sod and other organic debris, level the high spots with a flat shovel, and tamp the bed down.

LAY EXTERIOR PLYWOOD OR ANY SUITABLE DECK MATERIAL (5/8" 15,5 mm MINIMUM THICKNESS)

NOTE: Pressure Treated Lumber must not be used where it will make contact with your storage building. The properties of Pressure Treated Lumber will cause accelerated corrosion.

If Pressure Treated Lumber comes in contact with your storage building your warranty will be voided.

IMPORTANT NOTE: If leveling blocks are required due to uneven ground conditions, the floor frame kit must be completely supported, **because the kit is not self supporting.** Plywood rests on top of the floor frame.

Step 6 Placement & Amount of Material

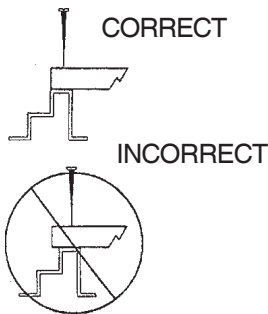

Drill and fasten wood to steel frames using dry wall screws

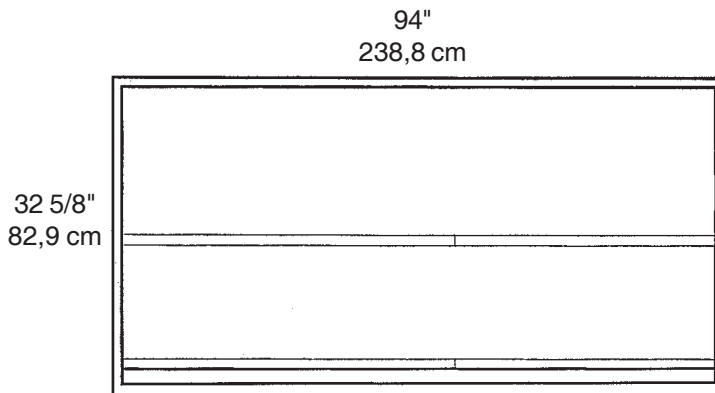

FRONT
1-4x8 1220x2440 mm SHEET
DECK MATERIAL

NOTE: ALIGN EDGE OF PLYWOOD WITH SIDE AND REAR FLOORFRAMES.

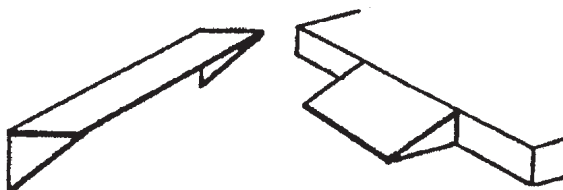

SUGGESTION: Use remaining decking material for shelving or entry ramp.

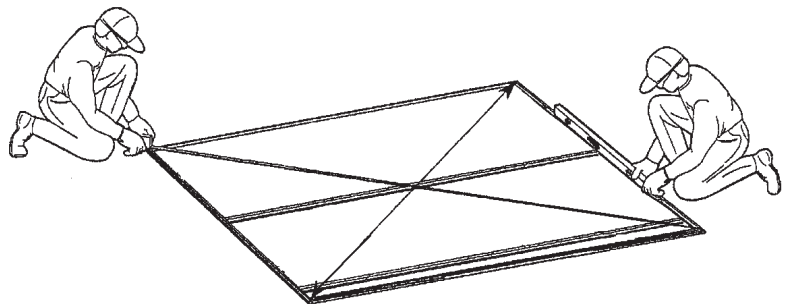

FRAME MUST BE SQUARE AND LEVEL BEFORE ATTACHING PLYWOOD.

Step 7

XZ15

● Parts Needed For ● Header/Door Header Assembly

- 10184 Main Door Header (1)
- 9947 Outer Door Header (1)
- 9945 Main Header (1)
- 9889 Outer Header (1)

The header assembly is made up of two pieces. The door header assembly is made up of two pieces. The illustrations below show the proper overall length for the header/door header assembly. Proceed as follows:

1 Place the **outer header** as shown. Snap the **main header** over the outer header. See the illustration for the proper overall length of the header assembly.

2 Place the **outer door header** as shown. Snap the **main door header** over the outer door header. See the illustration for the proper overall length of the door header assembly.

3 Double check the length of each.

The header/door header combo reinforces the front wall and roof. It is made up of two assemblies.

4 Positioning the door header as shown, attach the header to the door header using 13 screws along entire length. Set this piece aside for later use.

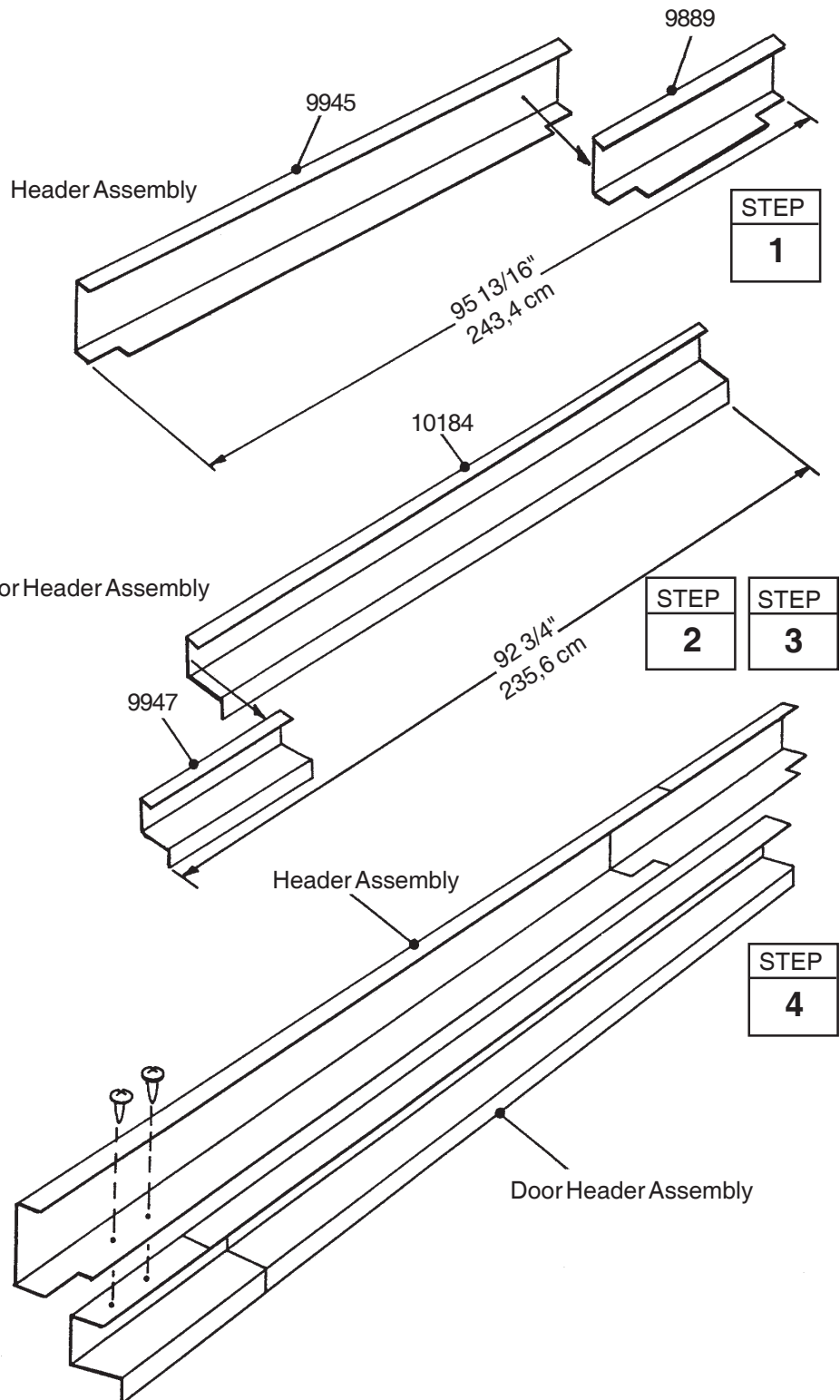

Step 8

XZ16

● Parts Needed For ● Roof Beam/Rear Wall Angle Assembly

- 9885 Roof Beam (2)
- 9883 Rear Wall Angle (2)

The main frame pieces reinforce the walls and roof. These pieces will later be installed in the center of the roof and at the top edge of the rear wall. Proceed as follows:

1 Overlap the **roof beam** pieces as shown in the figure (large hole on top) and fasten the two pieces together with four bolts and nuts where shown.

2 Overlap the **rear wall angle** pieces as shown in the figure and fasten them together with four bolts and nuts where shown.

3 Set the assemblies aside. You will use them later.

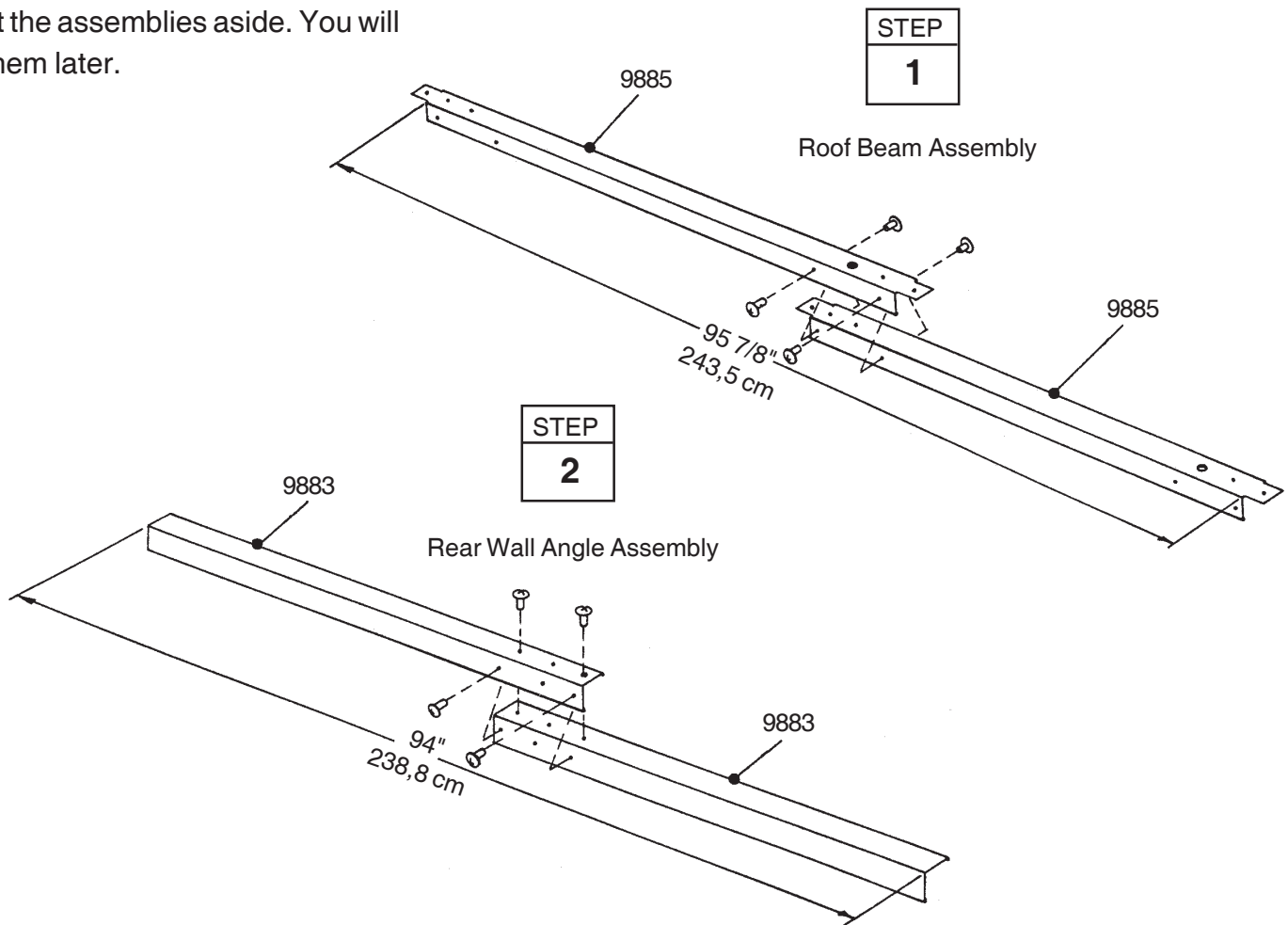

Step 9

XZ17

● Parts Needed For ● Right Door Assembly

- 9905 Door Brace (2)
- 9940 Right Door (1)
- 10183 Door Latch Brace (1)
- 10176 Astragal (1)
- 67734 Foam Board (1)
- 9944 Vertical Door Brace (1)
- 66054 Latch - Attic Door (1)

The steps on this page tell how to assemble the right door. Proceed as follows:

1 Position **hinges** on side of **right door panel** as shown and fasten with 7/16" (11 mm) flat head bolts outside and #6 hex nuts inside.

2 Slip **foam board** under lip of door, away from hinges, foil facing outward. See caution. Hold the **vertical door brace** against the long edge of the foam board inside the door and fasten to door using 5 bolts and nuts.

3 Position **astragal** to door, as shown, and fasten to side of door using six screws.

4 Cover ends of door panel with **door braces**. Edge of door panel slides into brace. Fasten braces to door using two screws on each brace.

5 Fasten **door latch brace** to door and astragal using four screws. Using an awl, ice pick or nail, push holes through foam board at the handle holes. Attach **locking handle** to door using 7/8" (22 mm) bolts.

6 Attach latch by inserting onto square shaft of handle.

7 Set the door aside for later use.

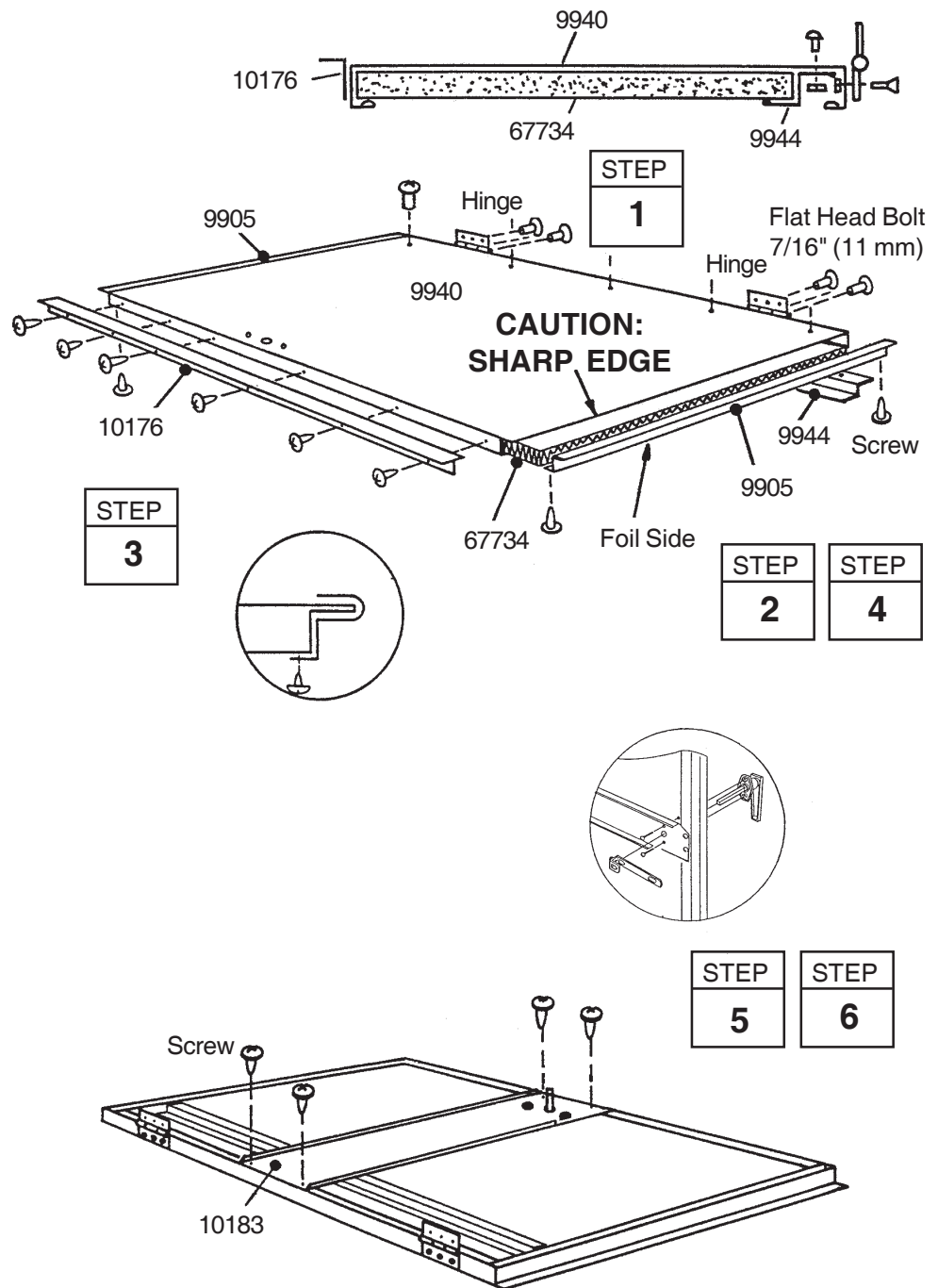

Step 10

XZ18

● Parts Needed For ● Left Door Assembly

- 9905 Door Brace (2)
- 9941 Left Door (1)
- 67734 Foam Board (1)
- 9944 Vertical Door Brace (1)
- 66684 Spring Latch (2)

The steps on this page tell how to assemble the left door. Proceed as follows:

1 Position **hinges** on side of **left door** panel as shown and fasten with 7/16" (11 mm) flat head bolts outside and #6 hex nuts inside.

2 Slip **foam board** under lip of door, away from hinges, foil facing outward. Hold the **vertical door brace** against the long edge of the foam board inside the door and fasten to door using five bolts and nuts.

3 Cover ends of door panel with **door braces**. Edge of door panel slides into brace. Fasten braces to hinged side of door using one screw on each brace.

4 Attach spring latches to door braces and door using three screws on each latch.

5 Set the door aside for later use.

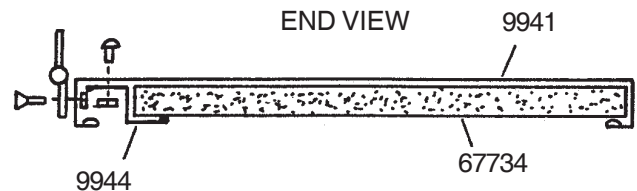

STEP
2

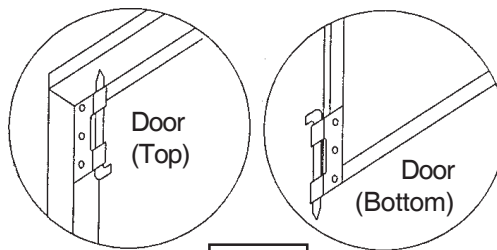

STEP
4

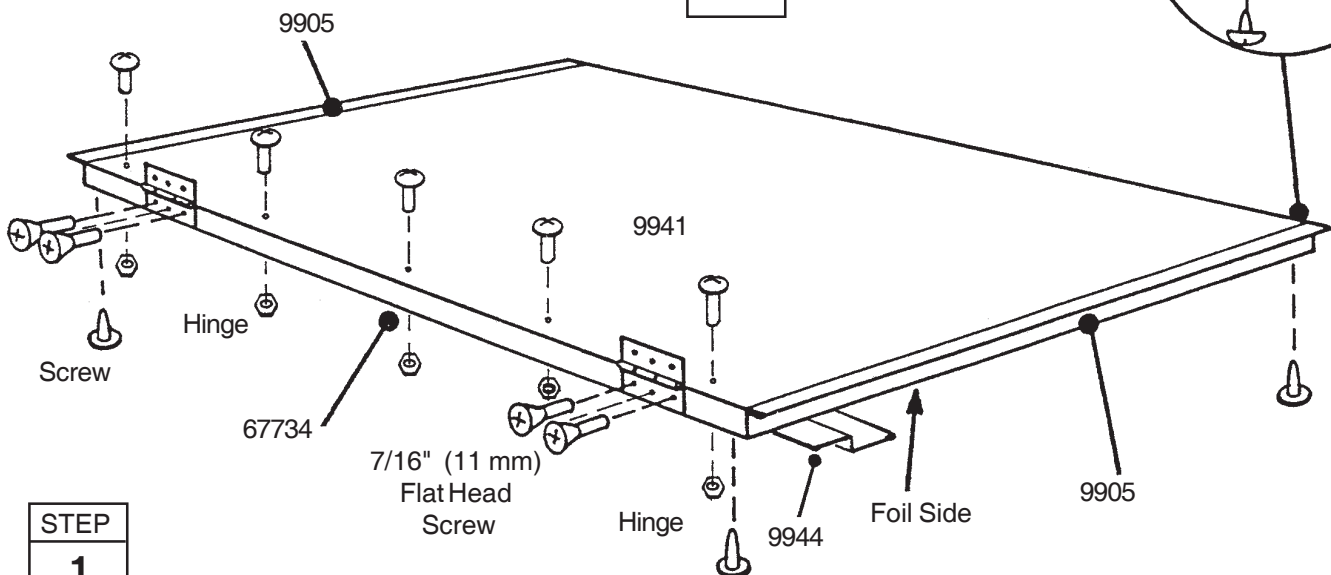
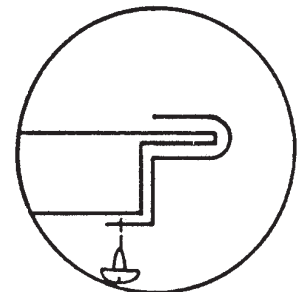

STEP
1

STEP
3

Step 11

XZ19

● Parts Needed For ● Corners/Gables

- 9870 Right Front Corner Panel (1)
- 9871 Left Front Corner Panel (1)
- 9872 Right Rear Corner Panel (1)
- 9873 Left Rear Corner Panel (1)
- 9874 Wall Panel (2)
- 9890 Right Gable (1)
- 9891 Left Gable (1)

NOTE

The remainder of the building assembly requires many hours. Do not continue beyond this point if you do not have enough time to complete the assembly today. A partially assembled building can be severely damaged by light winds.

Each screw and bolt in the wall requires a washer.



CORRECT



INCORRECT

1 Position **right & left front corner panels** at the corners of the floor frame as shown. The widest part of each corner panel must be placed along the front of the building. Fasten the corner panels to the floor frame with four screws, where shown.

Support the corner panel with a step ladder until next panel is fastened.

2 Attach the **right & left rear corner panels** to the rear corners, as shown.

NOTE

Be careful to install the correct panel in each position as shown

3 Fasten **wall panels 9874** to the sides of building using four screws into side floor frame. The crimped rib should go under the rib of adjacent panel. Fasten overlapping rib using two screws and a bolt with nut.

4 Fasten the **right & left gables** across the top of the side panels using five screws on each gable.

5 Double-check the part numbers of the wall panels, before proceeding.

STEP
2

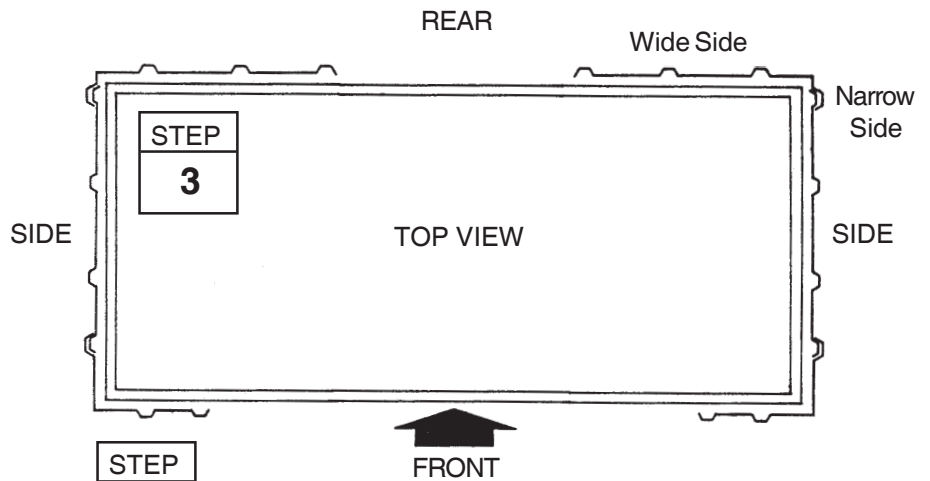

STEP
1

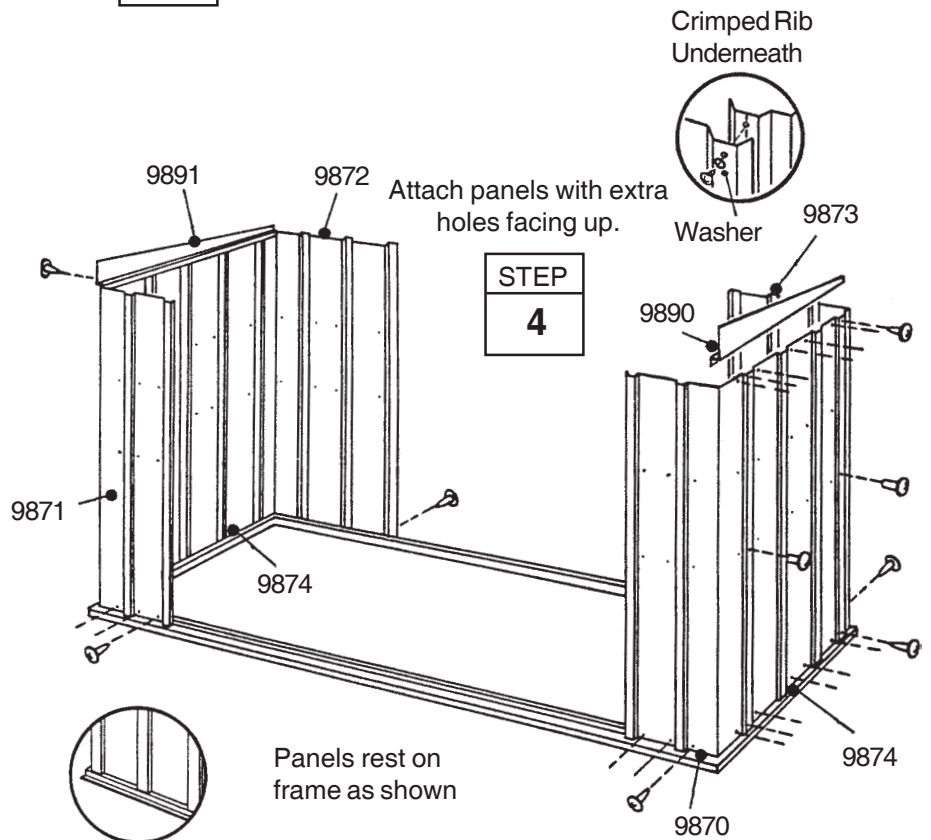

The floor frame *must be square and level* or holes will not align.

Step 12

XZ20

● Parts Needed For ● Frames

- Rear Wall Angle Assembly (1)
- Header/Door Header Assembly (1)

The main frame pieces give rigidity to the front and rear walls.

1 Fasten the **rear wall angle assembly** across the top of the rear wall using eight screws.

2 Fasten the **header/door header assembly** across the top of the front walls using six screws, where shown.

3 Join gables to header in the front corners, using a bolt and nut.

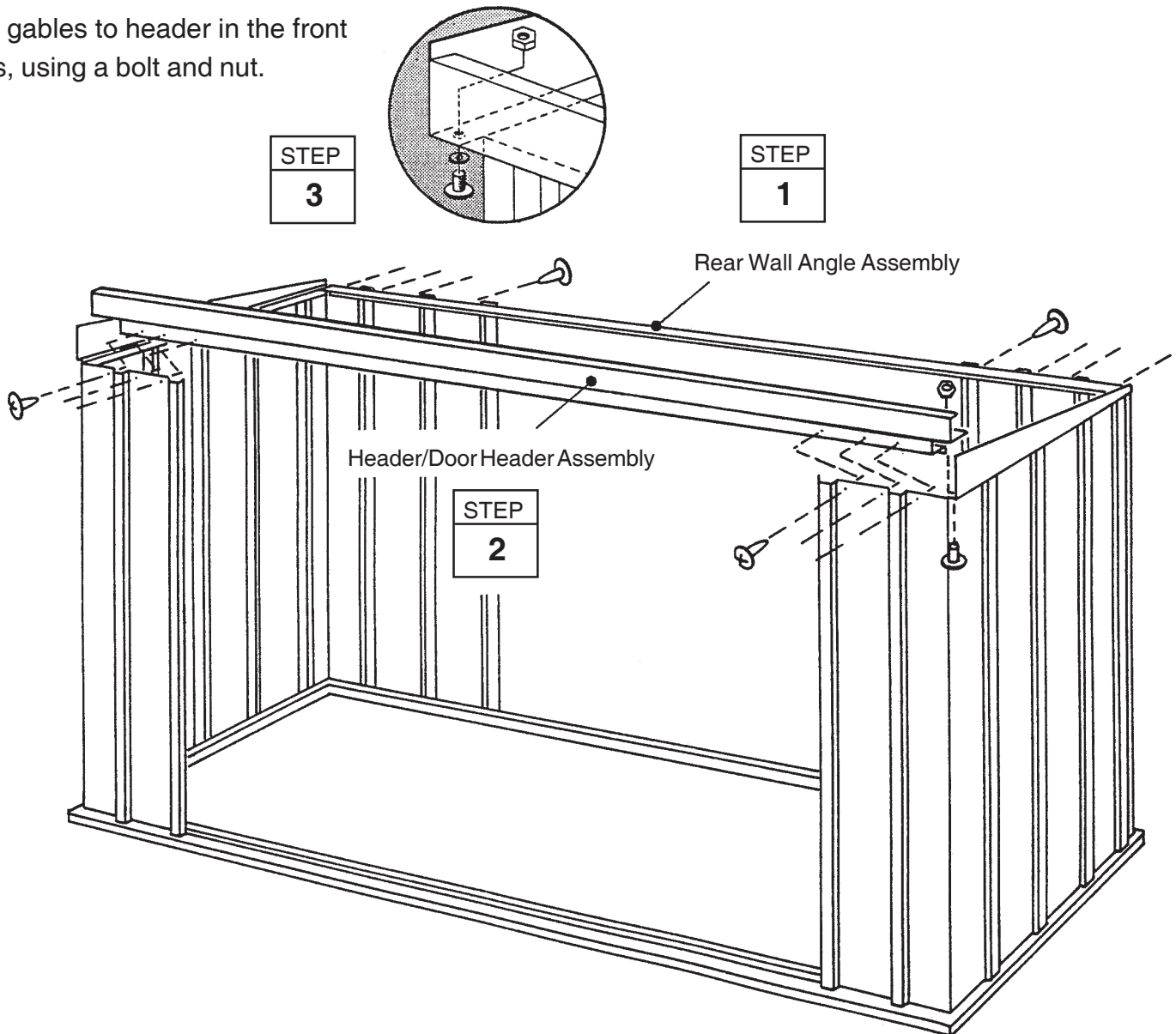

Step 13

XZ21

● Parts Needed For ● Wall Panels

- 9875 Front Wall Panel (2)
- 9876 Wall Panel (2)
- 9877 Wall Panel (1)

Each wall panel has a crimped rib on one side. The crimped rib should go under the rib of the adjacent panel that follows it.

1 Fasten all the **wall panels** at the top and bottom with screws. *Attach panels with extra holes facing up.*

2 Fasten overlapping ribs using two screws and a bolt with nut.

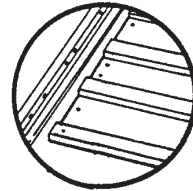

Be sure that you have the correct panel in each position. Do this by overlapping the panels and determining if the holes line up with the holes in the frame.

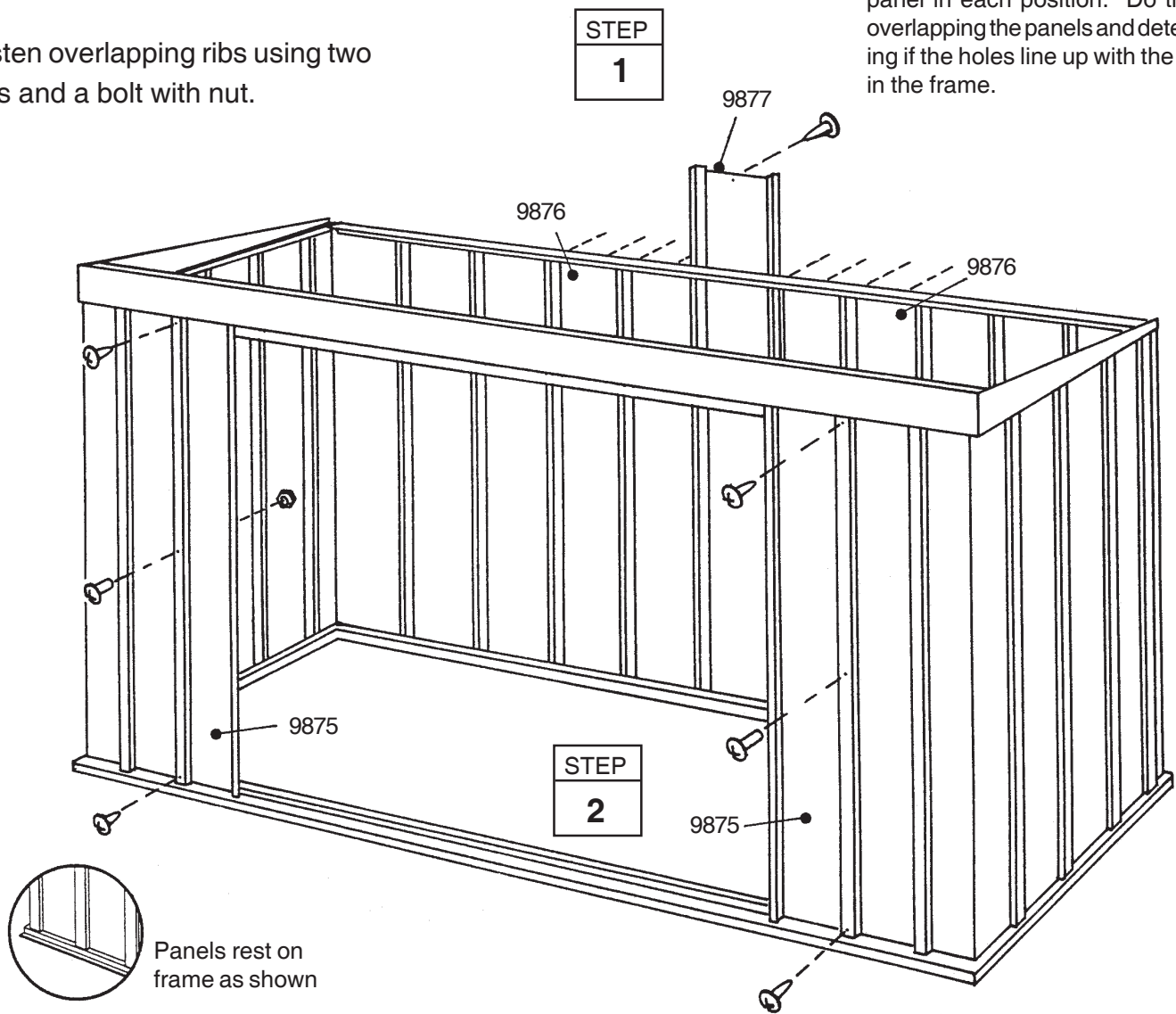

Panels rest on frame as shown

Crimped Rib Underneath

Step 14

XZ22

● Parts Needed For ● Door Jambs

- 9892 Right Door Jamb (1)
- 9893 Left Door Jamb (1)

The door jambs reinforce the door opening and provide an attractive trim. Follow these steps for both door jambs.

1 Fasten a **right door jamb** to the front wall panel with three bolts and nuts as shown.

2 Fasten the top of the door jamb to the door header with two screws. Do the same for the bottom into frame.

Repeat steps 1 through 2 for the opposite left door jamb.

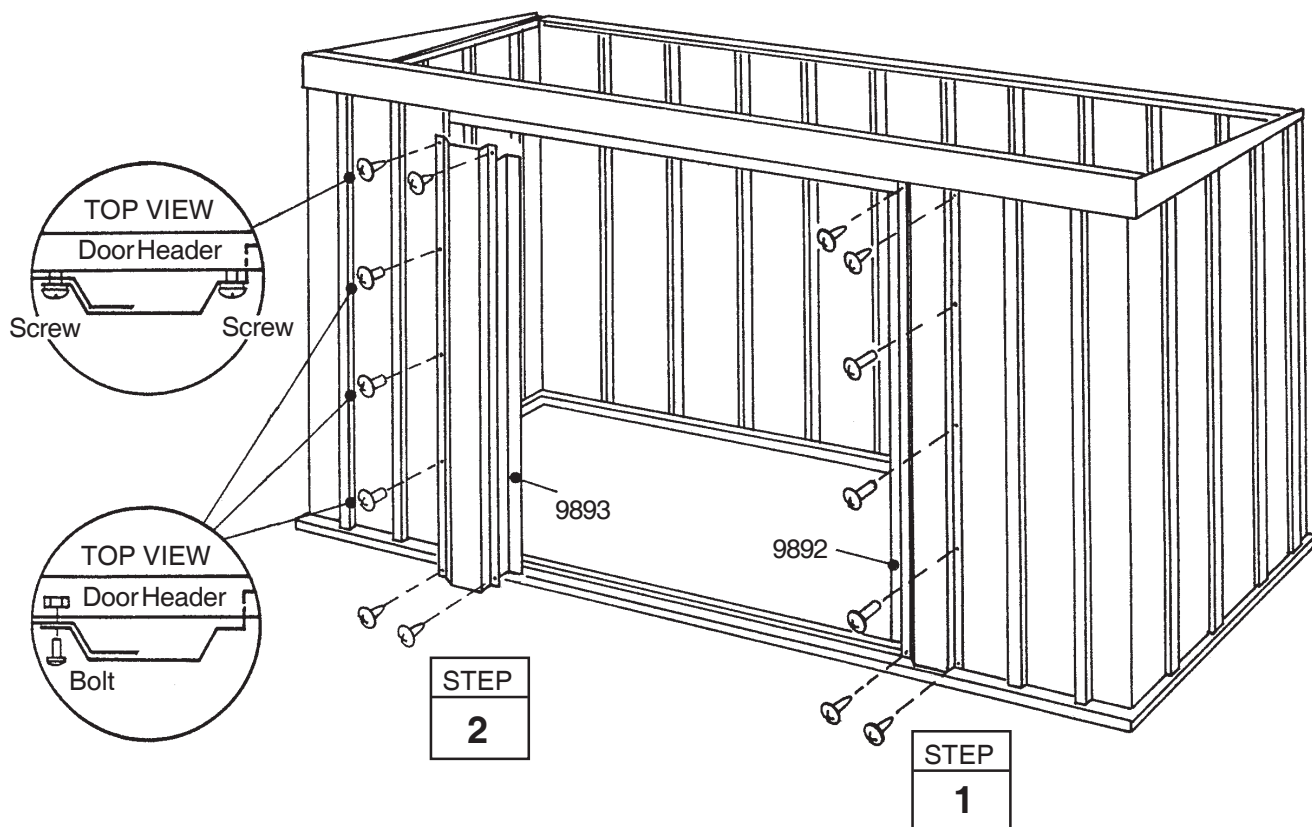

Step 15

XZ23

● Parts Needed For ●
Roof Beam

● Roof Beam Assembly (1)

1 Bend tab at each end of **roof beam assembly** upward. Position beam across width of building, down on the ledge of gables at center hole location, but do not fasten at this time.

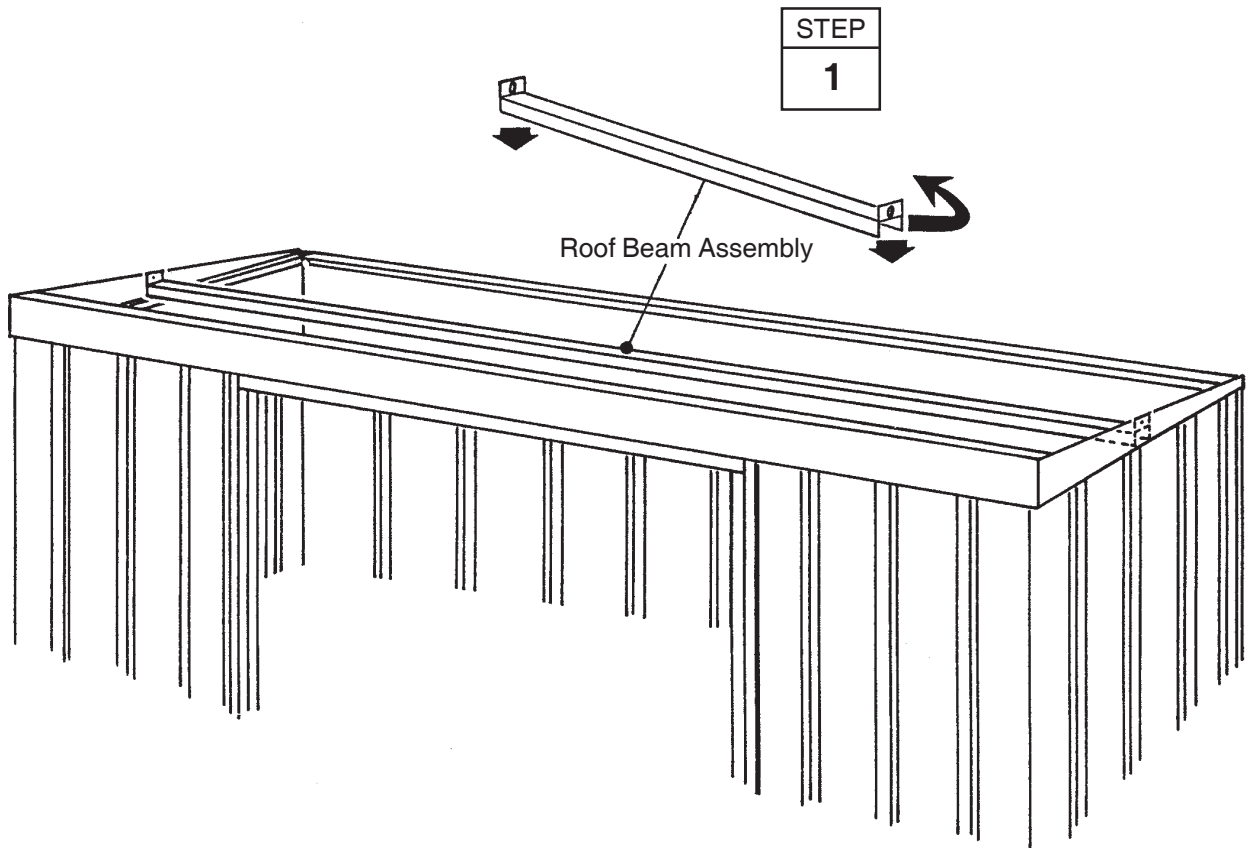

Step 16

XZ24

● Parts Needed For ● Right/Left Roof Panels

- 9878 Right Roof Panel (1)
- 9879 Left Roof Panel (1)

Installing the roof panels is best done with a step ladder. Begin installing roof panels at the right side of the building. Each screw and bolt in the roof requires a washer.

NOTE

Measure the building diagonally again and make adjustments to make sure the building is square and level. This will make the roof panels fit better, and holes will align.

1 Locate the roof panels and find the **right roof panel** part number **9878**.

2 Position a right roof panel at the right side and fasten to the gable, header and roof beam and rear wall angle using screws and bolts with nuts as shown.

Note: Tab of roof beam is fastened between roof panel and gable using the center hole.

3 Install the **left roof panel 9879** on the left side in the position shown below.

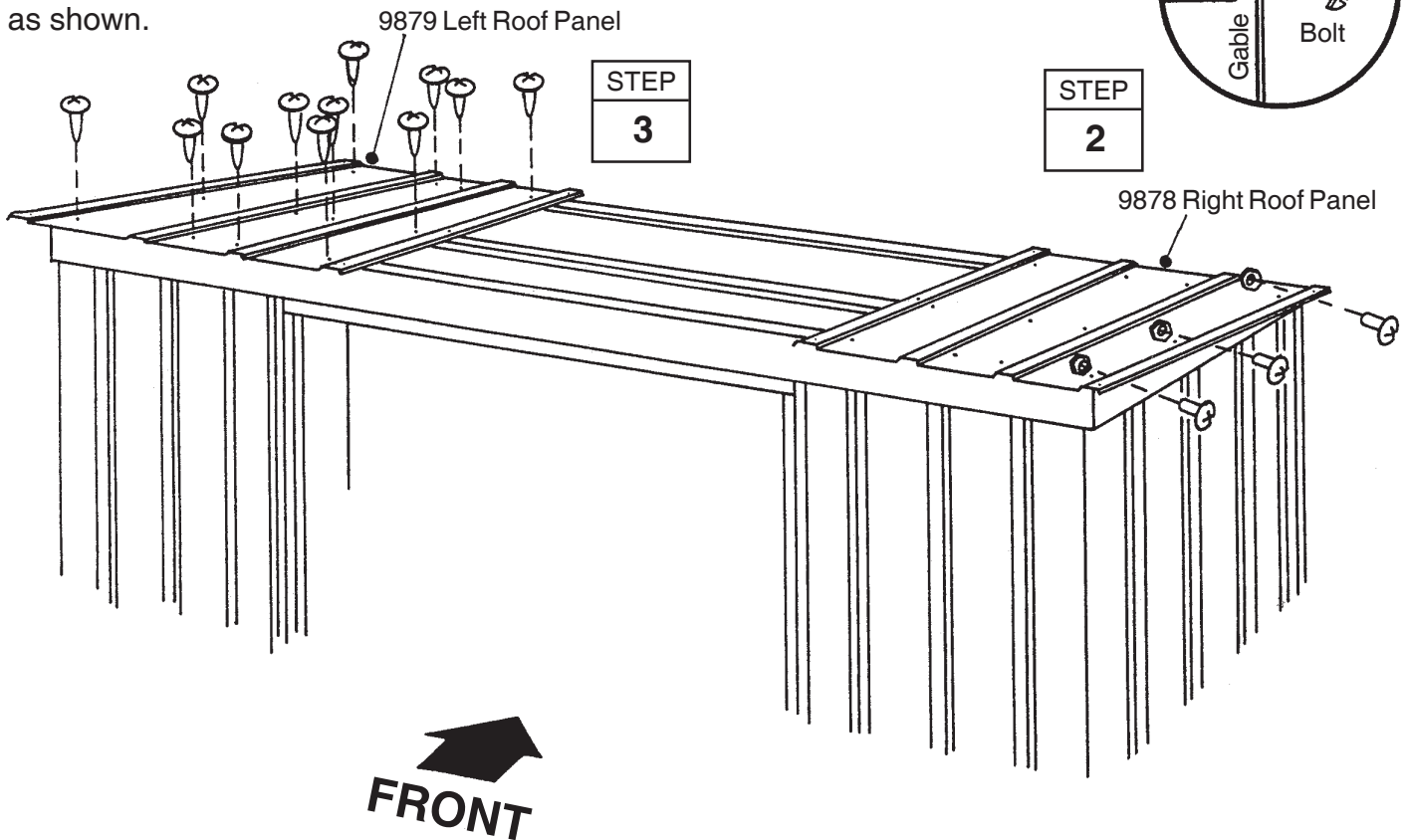
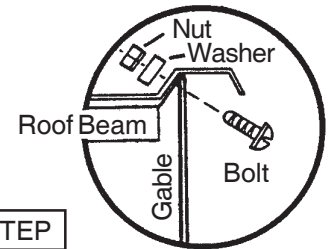
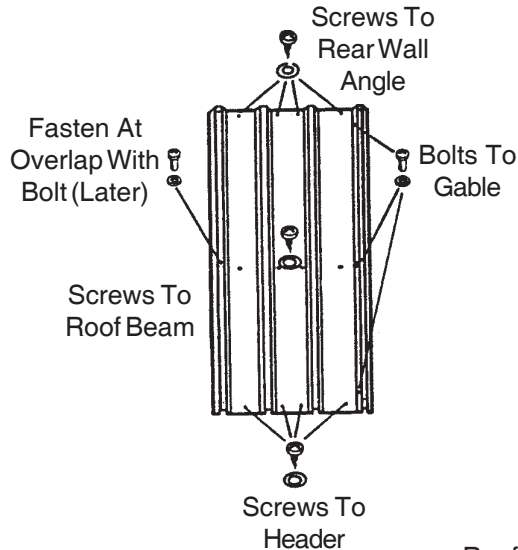

Step 17

XZ25

● Parts Needed For ● Roof Panels

- 9880 Roof Panel (2)
- 9881 Roof Panel (1)

1 Install a wide **roof panel 9880**, narrow **roof panel 9881**, and a wide **roof panel 9880** in the positions shown. Fasten middle of rib overlap with a bolt and nut.

Note:

Narrow roof panel crimped rib is overlapped by wide rib of adjacent panel where possible

STEP
1

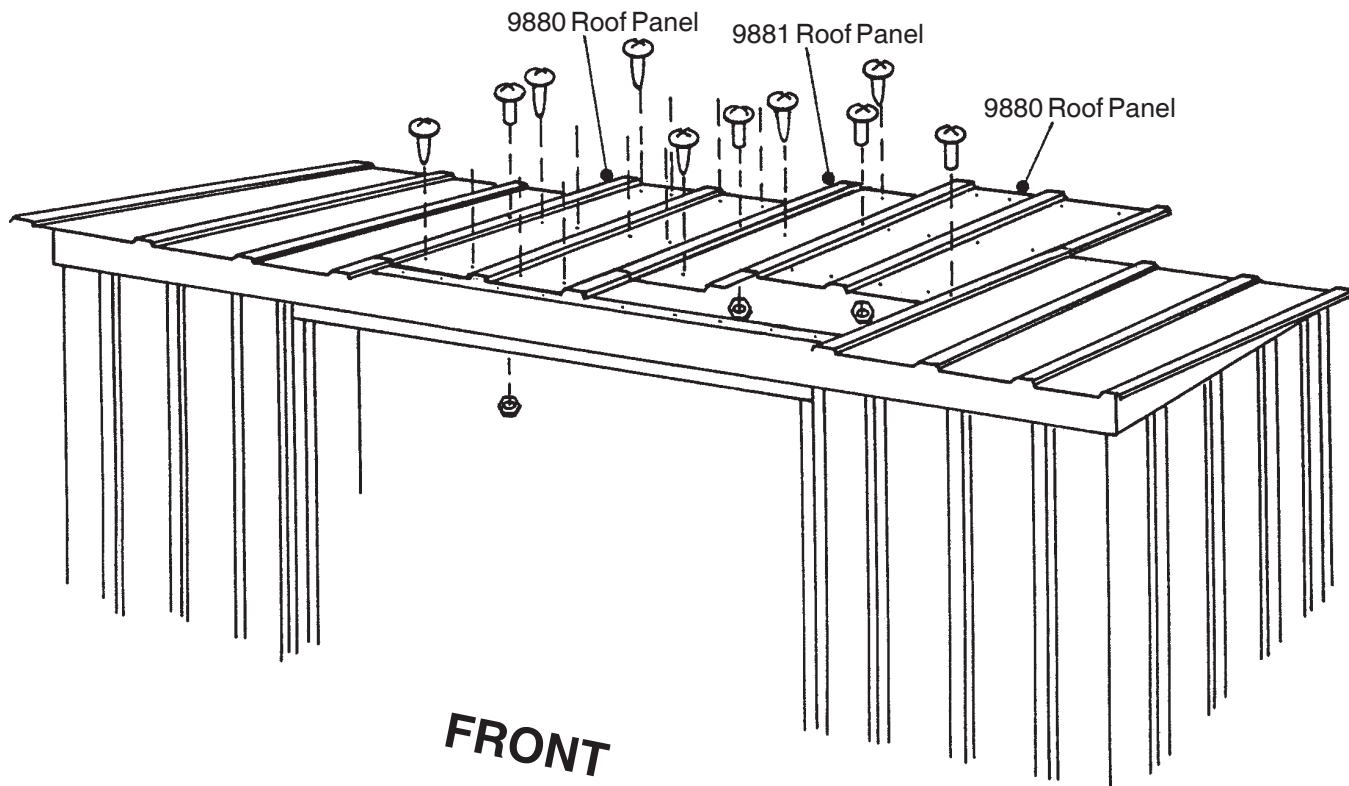

Step 18

XZ26

● Parts Needed For ● Roof Trim

- 9898 Right Roof Trim (2)
- 9899 Left Roof Trim (2)

1 Overlap the **right & left roof trim** pieces as shown in the figure and fasten them together with one screw. Make two assemblies.

2 Attach the **roof trim assemblies** to the ends of the roof panels on the front and rear of the building using screws at each roof panel overlap.

3 Using your thumb and index finger, overbend the bottom flange of the roof trim at the corner inward enough so the **right and left roof trim caps** fit onto right and left corners.

4 Fasten the roof trim caps to the roof trim using a screw.

5 Fasten the roof trim and **peak cap** together using bolts and nuts.

6 Fasten the **corner caps** to the ends of the header, using adhesive pads.

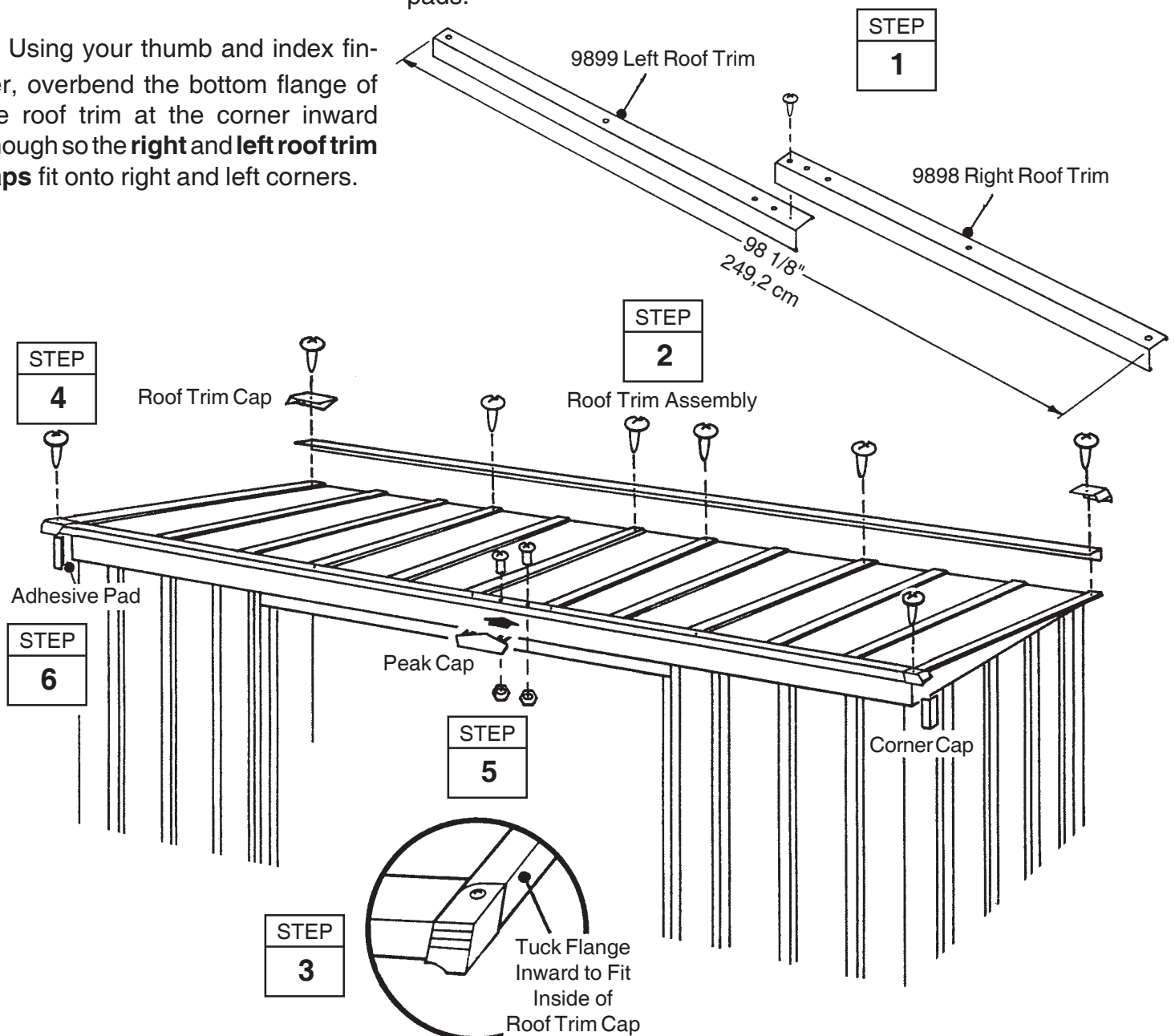

Step 19

XZ27

● Parts Needed For ● Shelving/Channel/Tool Bar

- 9927 Rear Wall Channel (2)
- 9884 Shelf (4)
- 9897 Tool Bar (1)

1 Overlap the **rear wall channel** pieces as shown in the figure to the correct overall dimension.

2 Fasten the **rear wall channel assembly** across the middle of the rear wall using 13 screws.

3 Position a **shelf** inside rear wall channel and slide to the end of building. Fasten using ten bolts and nuts through panels.

Repeat Step 3 for the *opposite* shelf.

4 Install remaining two **shelves** above the first two at the holes provided, using ten bolts and nuts.

5 Fasten the **tool bar** across the upper rear wall using eleven screws from the outside.

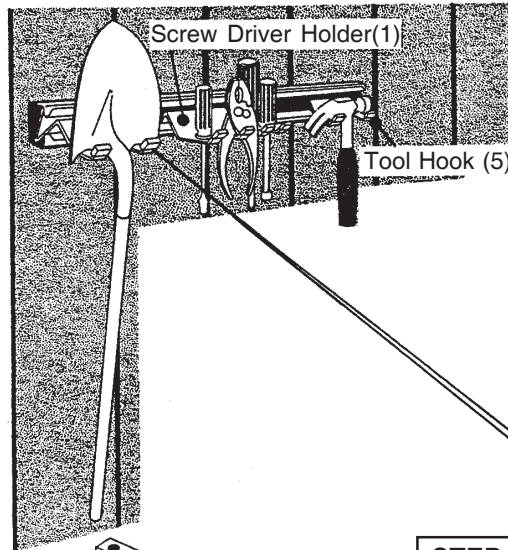

Tool Hooks slide along track to any desired position. Keeps rakes, shovels, brooms and much more in a safe and accessible location.

The Screw Driver Holder is engineered for all types of hand tools such as screwdrivers and pliers. A total of seven hand tools may be stored.

Install Cap Protectors to the ends of the Tool Hooks and Screw Driver Holder.

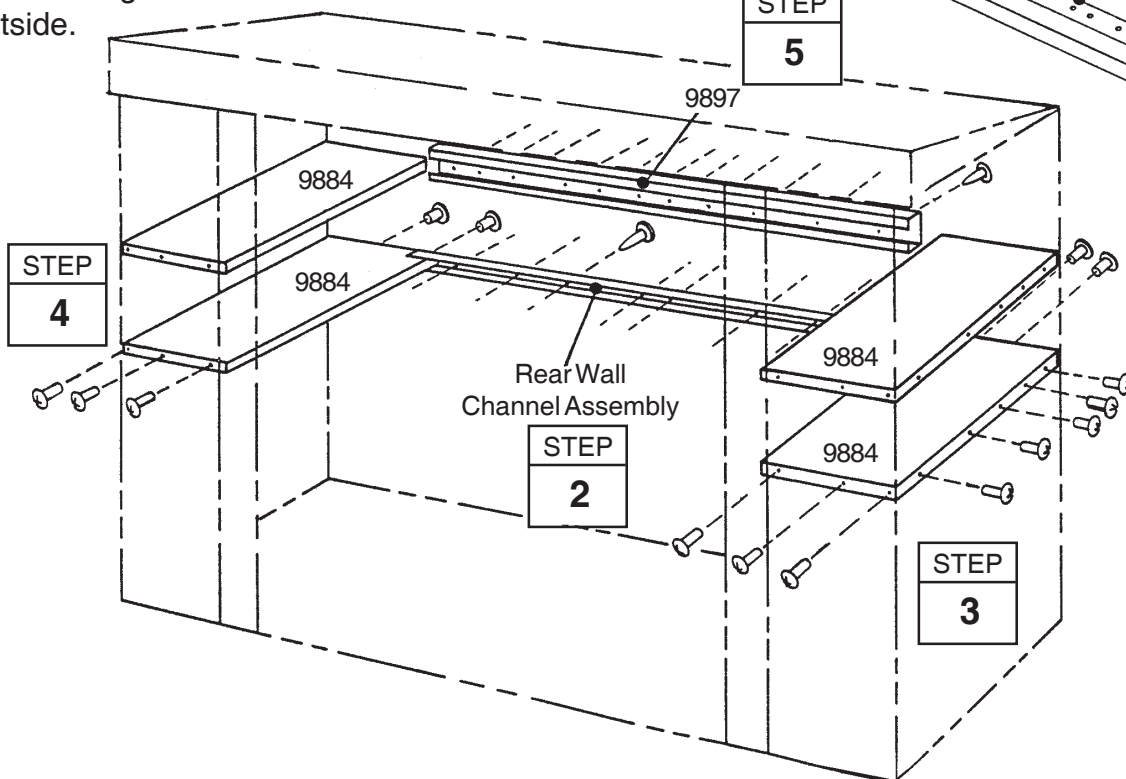
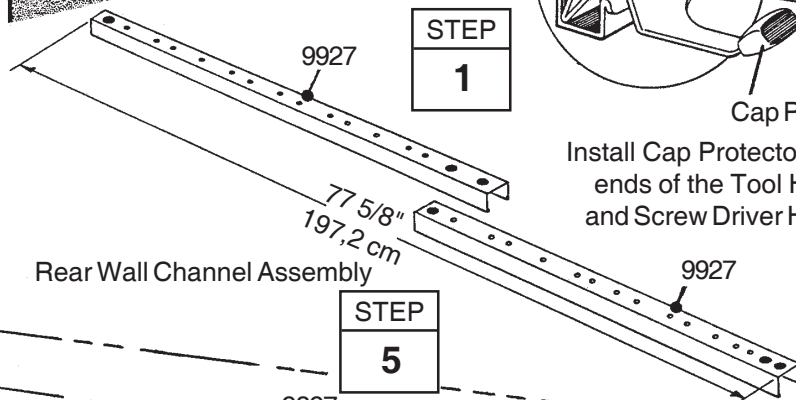

Step 20

XZ28

● Parts Needed For ● Installing Door

- Right Door Assembly (1)
- Left Door Assembly (1)

1 Position doors in corners of door opening as shown and fasten hinges to jambs with 7/16" (11 mm) flat hd bolts and #6 hex nuts.

2 Close doors. Adjust so that latch engages behind left door, then tighten set screw. The unit is locked. Turn key and remove.

Congratulations, you have completed assembly of your storage building.

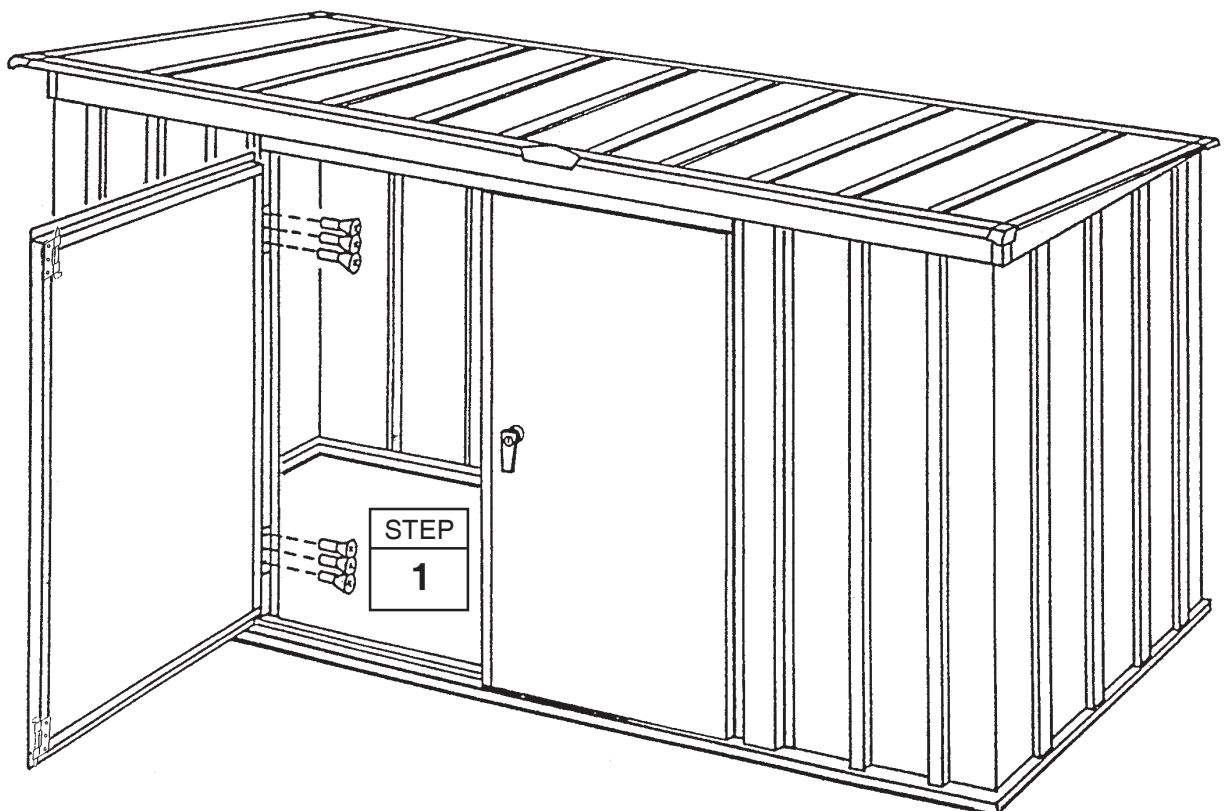
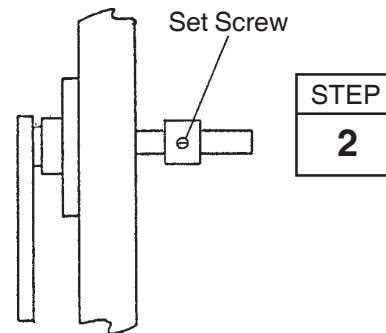

Keep this Owner's Manual and Assembly Instructions for future reference.

GSA83

Anchoring

Anchor your building at this time.

SOME FACTS ABOUT RUST

Rusting is a natural oxidizing process that occurs when bare metal is exposed to moisture. Problem areas include screw holes, unfinished edges, or where scrapes and nicks occur in the protective coating through normal assembly, handling and use. Identifying these natural rusting problem areas and taking some simple rust protection precautions can help to stop rust from developing, or stop it quickly as soon as it appears.

1. Avoid nicking or scraping the coating surface, inside and out.
2. Use all the washers supplied. In addition to protecting against weather infiltration, the washers protect the metal from being scraped by the screws.
3. Keep roof, base perimeter and door tracks free of debris and leaves which may accumulate and retain moisture. These can do double damage since they give off acid as they decay.
4. Touch up scrapes or nicks and any area of visible rust as soon as possible. Make sure the surface is free of moisture, oils, dirt or grime and then apply an even film of high quality touch-up paint.